



DC 输入侧



使用手册



影片



AC 输出侧

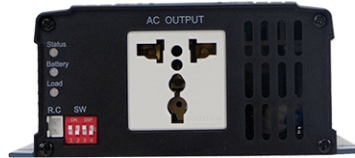

IEC62368-1 BS EN/EN62368-1

TPTC004

AS/NZS 62368.1

详情请参阅第3页.

## 特性

- 体积小, 重量轻
- 采纯正弦波输出 (THD<3%)
- 瞬间输出功率高达600W
- 无风扇
- 交流输出电压和频率可由DIP S.W选择
- 待机省电模式下空载功耗<1.5W max
- -25°C~+65°C宽工作温度
- 电源开/关远程控制
- 显示操作状态的前面板指示灯
- 保护:
  - 输入: 反极性/直流低压警报/直流低压关机/过压
  - 输出: 短路/过载/过温。
- 电池过放电保护(低压断开)
- 适用于铅酸电池或锂离子电池
- 提手配件(订单号: Carry handle, 单独销售)
- 保形涂层
- 3年长效保固

## 描述

NTS-300是一款300W高信赖离网纯正弦波DC-AC逆变器。其主要功能包括:单片机控制的数字设计、快速响应工况变化的新型控制电路、可靠性高、600W峰值功率、交流输出电压和频率可调、-25~+65°C宽工作温度范围、完整的保护功能等等。结合电池, NTS-300适用于住宅、商业、船舶、汽车、矿山、建筑工地和没有公用电源设施的偏远地区, 输出可用于风扇、电视、收音机、手机充电器、笔记本电脑、照明、机电工具、通讯设备、配电柜、户外露营设备、船舶交流电源、工厂设备等。

## 型号编码

NTS - 300 - 1 12 US

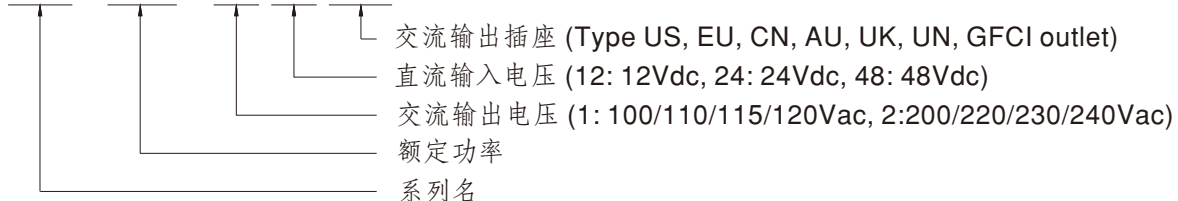

## 应用

- 移动设备
- 家居办公用品
- 电动工具
- 便携设备
- 车辆
- 游艇
- 离网太阳能发电系统
- 无线网络
- 电信或数据通讯系统

## 电气规格

型号		NTS-300-112□	NTS-300-124□	NTS-300-148□	NTS-300-212□	NTS-300-224□	NTS-300-248□		
		□ = US, GFCI, UN			□ = EU, CN, AU, UK, UN				
AC输出	额定功率(连续)	300W							
	过功率(3分钟)	345W							
	峰值功率(10秒)	450W							
	瞬间功率(30周期)	600W							
	交流电压	出厂设定在 110VAC 100 / 110 / 115 / 120Vac 可由DIP S.W选择			出厂设定在 230VAC 200 / 220 / 230 / 240Vac 可由DIP S.W选择				
	频率	出厂设定在 60Hz±0.1Hz 50/60Hz 可由DIP S.W选择			出厂设定在 50Hz±0.1Hz 50/60Hz 可由DIP S.W选择				
	波形 备注1	纯正弦波 (THD<3%)							
	交流调整率	额定输出电压的±3.0%							
前面板LED	请参考第5页								
DC输入	直流电压	12V	24V	48V	12V	24V	48V		
	电压范围 (Typ.)	10 ~ 16.5Vdc	20 ~ 33Vdc	40 ~ 66Vdc	10 ~ 16.5Vdc	20 ~ 33Vdc	40 ~ 66Vdc		
	直流电流 (Typ.)	30A	15A	8A	30A	15A	8A		
	空载功耗 (Typ.)	非省电模式	10W	10W	12W	10W	10W	12W	
		省电模式	默认不可用, ≤1.2W ~ 1.5W 自动检测交流输出负载 ≤10W 将切换为省电模式						
			1.2W	1.3W	1.5W	1.2W	1.3W	1.5W	
	关机模式电流	≤1mA							
	效率(Typ.) 备注1	90%	92%	92%	92%	93%	93%		
电池类型	铅酸或锂离子电池								
保护	DC输入	保险丝(内部)	30A*2	30A*1	10A*2	30A*2	30A*1	10A*2	
		低压	报警	11±0.3Vdc	22±0.5Vdc	44±1Vdc	11±0.3Vdc	22±0.5Vdc	44±1Vdc
			关机	10±0.3Vdc	20±0.5Vdc	40±1Vdc	10±0.3Vdc	20±0.5Vdc	40±1Vdc
			重启	12.5±0.3Vdc	25±0.5Vdc	50±1Vdc	12.5±0.3Vdc	25±0.5Vdc	50±1Vdc
		高压	报警	15.5±0.3Vdc	31±0.5Vdc	62±1Vdc	15.5±0.3Vdc	31±0.5Vdc	62±1Vdc
			关机	16.5±0.3Vdc	33±0.5Vdc	66±1Vdc	16.5±0.3Vdc	33±0.5Vdc	66±1Vdc
	重启		15±0.3Vdc	30±0.5Vdc	60±1Vdc	15±0.3Vdc	30±0.5Vdc	60±1Vdc	
	电池反接	通过内部保险丝断开							
	AC输出	过温度	保护模式:关闭输出电压, 重启后恢复						
		输出短路	保护模式:关闭输出电压, 重启后恢复						
过负载(Typ.)		负载的105~115%持续180秒, 115~150%持续10秒							
GFCI防护		设计参考 UL458 (仅适用于“GFCI”交流插座)			无				
功能	遥控	前面板干触点连接器(继电器)远程控制电源开关, 开路:正常工作; 短路:遥控关闭							
环境	工作温度	-25 ~ +65°C(请参考“降额曲线”)							
	工作湿度	20 ~ 90% RH, 无冷凝							
	储存温度、湿度	-30 ~ +70°C / -22 ~ +158°F, 10 ~ 95% RH, 无冷凝							
	耐振动	10 ~ 500Hz, 3G 10分钟/周期, X、Y、Z轴各60分钟							
安规和电磁兼容 (备注4)	安全规范	CB IEC62368-1, Dekra BS EN/EN62368-1, E13, EAC TP TC 004 认证通过; 设计参考 AS/NZS 62368.1 (详情请参阅下一页“交流输出插座”表); 设计参考 UL458(按要求)							
	耐压	DC I/P - AC O/P: 3.0kVac AC O/P - FG: 1.5kVac							
	电磁干扰	Parameter	Standard				Test Level / Note		
		Radiated	FCC for 112, 124, 148 only(expect for Type-UN)				Class A		
			BS EN/EN55032(CISPR32) for 212, 224, 248 only(expect for Type-UN)				Class A		
		Harmonic Current	BS EN/EN61000-3-2				-----		
	Voltage Flicker	BS EN/EN61000-3-3				-----			
	电磁耐受	BS EN/EN55024, BS EN/EN55035							
Parameter		Standard				Test Level / Note			
ESD		BS EN/EN61000-4-2				Level 3, 8kV air; Level 2, 4kV contact			
Radiated		BS EN/EN61000-4-3				Level 2, 3V/m			
Magnetic Field	BS EN/EN61000-4-8				Level 1, 1A/m				
其它	MTBF	845.6K hrs min. Telcordia TR/SR-332 (Bellcore); 85.3K hrs min. MIL-HDBK-217F (25°C)							
	尺寸	210*130*55mm (L*W*H)							
	包装	1.3Kg; 8pcs/ 11.4Kg/ 1.74CUFT							
备注	<p>1.效率、交流调整率和THD是在12.5V, 25V, 50V输入电压、300W线性负载条件下测得。</p> <p>2.如未特别说明, 所有规格参数在额定负载, 25°C环境温度下, 设置成出厂设置的情况下进行量测。</p> <p>3.内部含有预启动线路, 开机时间8s。</p> <p>4.电源应视为一个独立的元件, 需结合终端设备进行电磁兼容相关确认。有关EMC测试操作指导, 请参阅“电源供应器EMI测试声明书”。(在明纬网站<a href="https://www.meanwell.com/Upload/PDF/EMI_statement_cn.pdf">https://www.meanwell.com/Upload/PDF/EMI_statement_cn.pdf</a>)</p> <p>※ 产品免责声明: 详情请参阅 <a href="http://www.meanwell.cc/serviceDisclaimer.aspx">http://www.meanwell.cc/serviceDisclaimer.aspx</a></p>								

## 交流输出插座

型号	NTS-300-112 <input type="checkbox"/>	NTS-300-124 <input type="checkbox"/>	NTS-300-148 <input type="checkbox"/>	NTS-300-212 <input type="checkbox"/>	NTS-300-224 <input type="checkbox"/>	NTS-300-248 <input type="checkbox"/>		
插座类型								
	TYPE-US	TYPE-GFCI	TYPE-UN	TYPE-EU	TYPE-CN	TYPE-UK	TYPE-AU	TYPE-UN
国家	美国	美国	全球通用	欧洲	中国	英国	澳大利亚	全球通用
认证			None					
	有现货	可选购	有现货	有现货	有现货	可选购	可选购	有现货

## 减额曲线

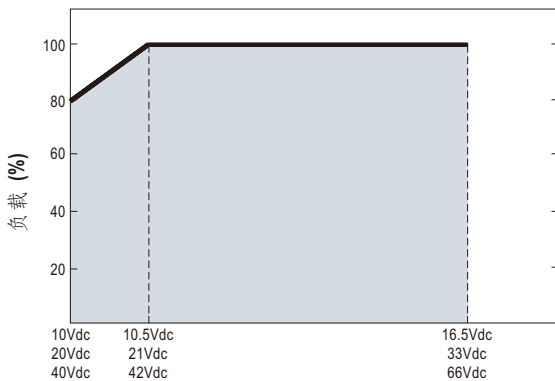
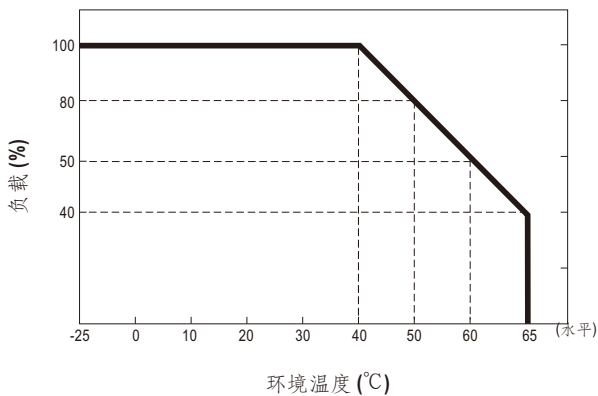

### ■ 遥控ON-OFF开关

遥控ON-OFF开关	AC输出状态
开路	正常工作
短路	停止工作

### ■ 交流输出电压、频率、省电模式可通过DIP SW选择



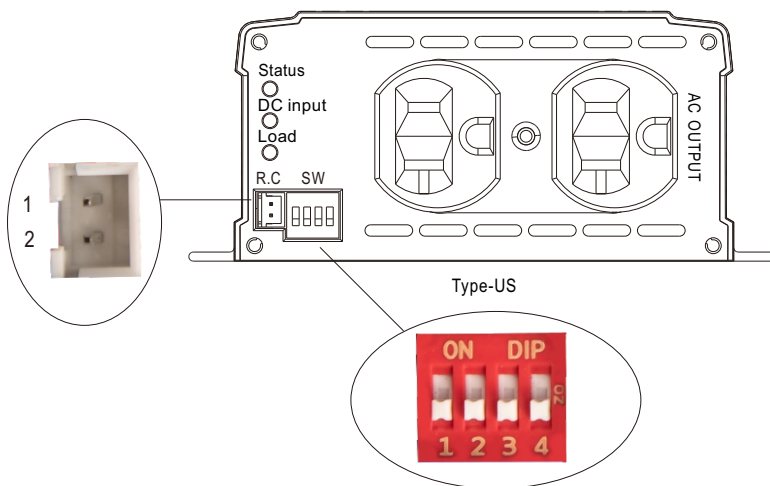

出厂设置为110Vac/60Hz或230Vac/50Hz，用户可通过拨码开关位置1、2、3、4来调节电压和频率。















交流输出电压、频率、省电模式可通过DIP SW选择			
SW1	SW2	SW3	SW4
OFF	OFF : 100Vac or 200Vac	ON : 50Hz	ON : 省电模式
OFF	ON : 110Vac or 220Vac		
ON	OFF : 115Vac or 230Vac	OFF: 60Hz	OFF: 非省电模式
ON	ON : 120Vac or 240Vac		

■ LED 灯号说明











正常工作:

状态	绿色	橙色	红色
	 系统检测  正常工作	 遥控断电  省电模式	 报警状态 (见下表)

直流输入	绿色	橙色	红色
	 12.5~15.5Vdc  25~31Vdc  50~62Vdc	 11~12.5Vdc  22~25Vdc  44~50Vdc	 <11Vdc or >15.5Vdc  <22Vdc or >31Vdc  <44Vdc or >62Vdc

负载	绿色	橙色	红色
	 <40% 负载	 40~80% 负载	 >80% 负载

报警模式:

LED显示器	报警显示器
状态  DC 输入  负载 	输出过载或交流输出短路
状态  DC 输入  负载 	直流电压异常
状态  DC 输入  负载 	过温或风扇锁住
状态  DC 输入  负载 	逆变器故障

-  恒亮
-  熄灭
-  闪烁

■ 机构尺寸

Unit:mm

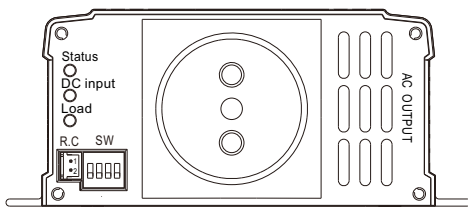
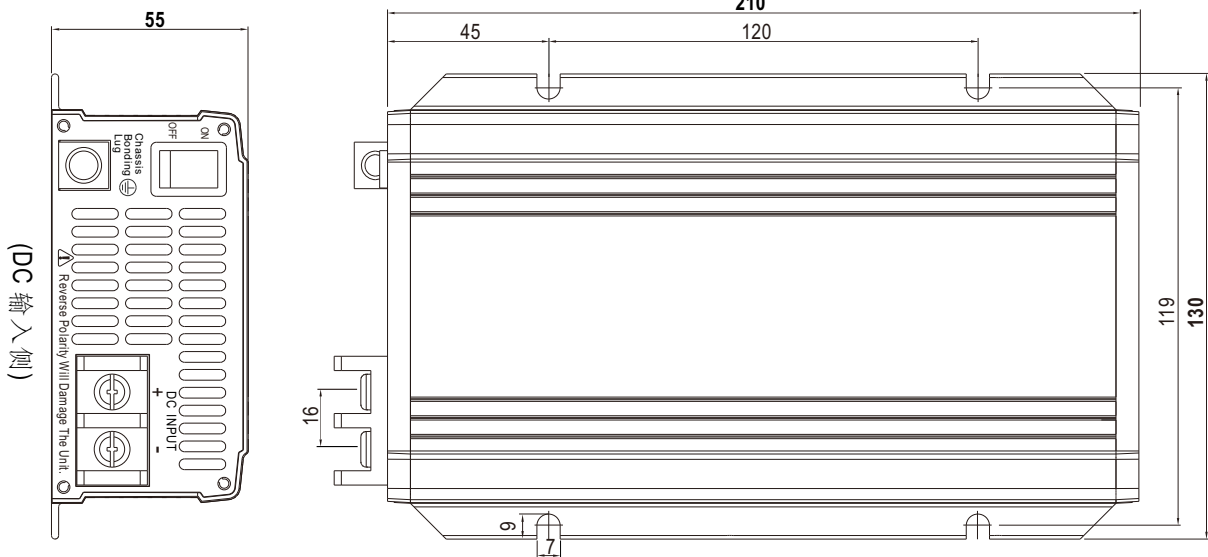

Type-EU

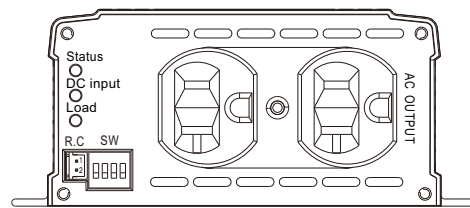

Type-US

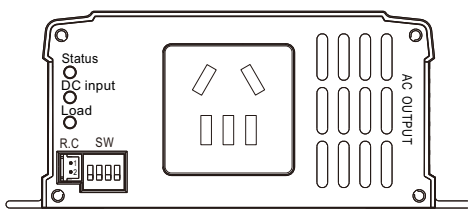

Type-CN

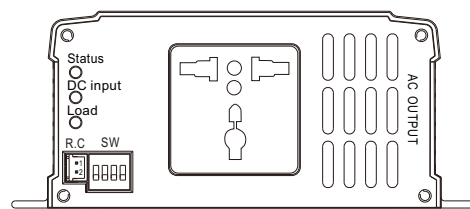

Type-UN



(AC 输出侧)

R.C 连接器: JSTB-XH 或同等级品

远程控制	匹配端子	端子型号
Pin 1,2 开路: 正常工作	JST XHP 或同等级品	JST SXH-001T 或同等级品
Pin 1,2 短路: 遥控关闭		

### ■ 配件列表

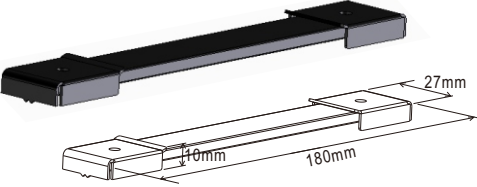
※ 提手(选配配件，逆变器和提手需单独订购)

明纬订单编号	物件		数量
Carry Handle	①	提手 	1
	②	脚垫 	4
	③	螺丝 	2

① 提手

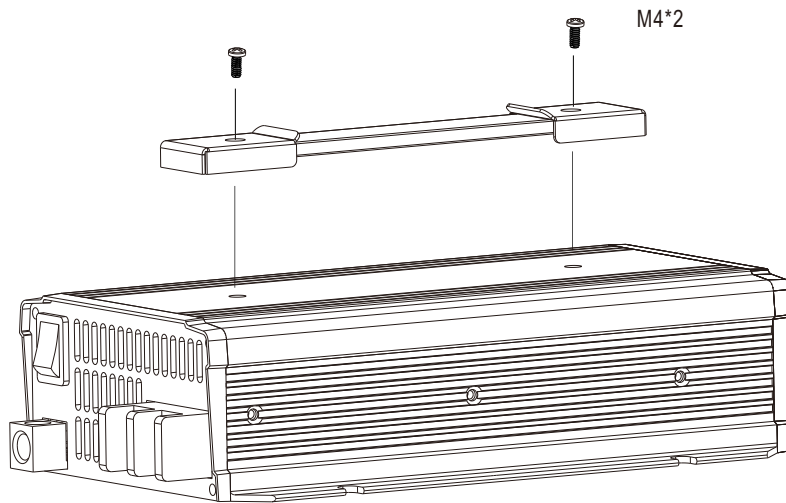

② 脚垫

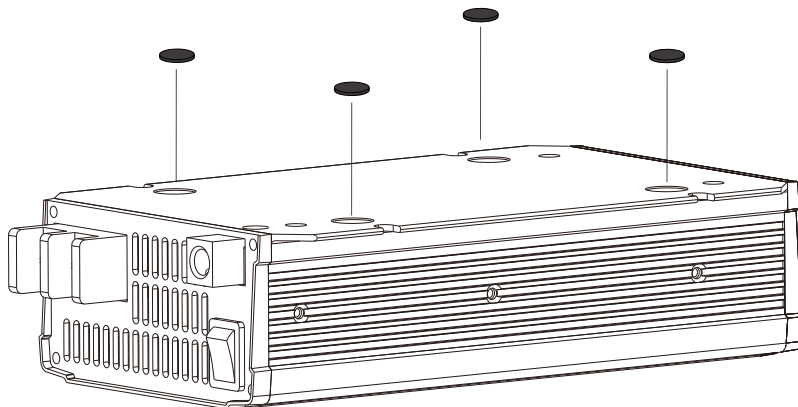

## 典型应用

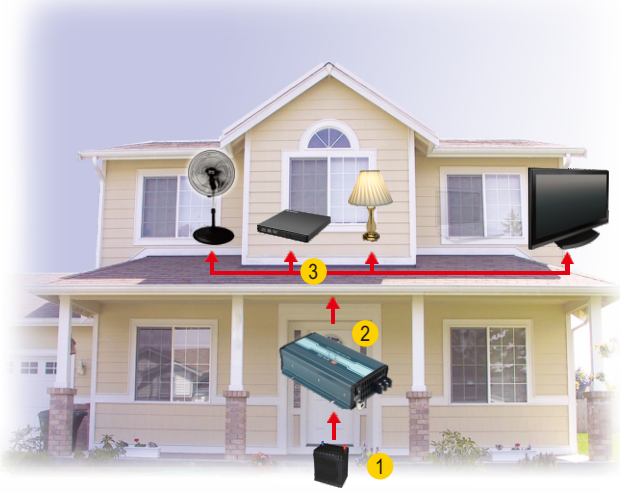

- ① 电池组
- ② 离网DC/AC太阳能逆变器(NTS系列)
- ③ AC 插座



- ① 实用程序输入(海岸)
- ② AC/DC 电池充电器(PB/NPB/NPP 系列)
- ③ 电池组
- ④ 离网DC/AC 逆变器(NTS 系列)
- ⑤ AC 插座

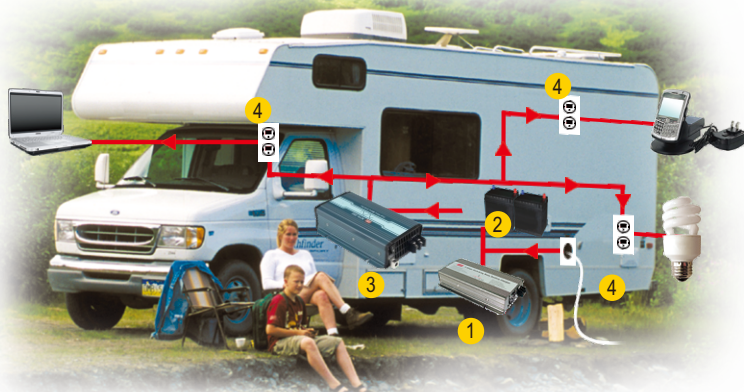

- ① AC/DC 电池充电器(PB/NPB/NPP 系列)
- ② 电池组
- ③ 离网DC/AC逆变器(NTS 系列)
- ④ AC 插座