

# 电缆线固定头

## 金属型

| 代码    | 类型  | 材质    |      | 防护等级 | 使用温度       |
|-------|-----|-------|------|------|------------|
| ZIL43 | 金属型 | A、C、F | 黄铜镀镍 | IP68 | -40~+100°C |
|       |     | B、E   | 硅胶   |      |            |
|       |     | D     | PA尼龙 |      |            |

特点:

- 适用于薄型机板的开孔或附有内螺纹的设备上;
- 特殊夹紧爪与夹紧圈凹凸相扣设计, 配合迫紧头装配时省时便利, 夹紧电缆范围大、抗拉力强;
- 防水、防尘、抗盐、耐酸碱、酒精、油脂及一般溶剂。

使用方法:

- 金属电缆线固定头是电缆的配套产品, 接头可将电缆锁紧, 另一端可接入设备箱体上, 也可根据选用螺纹接入进出口为内螺纹的电动设备上。

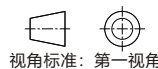
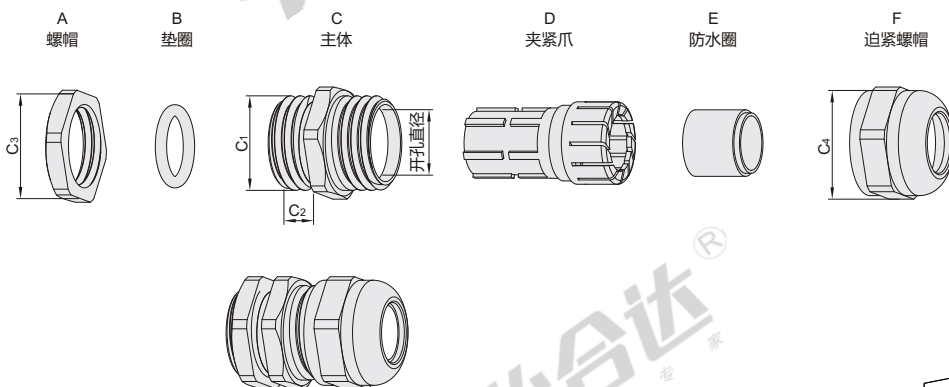

| 代码    | 型号     | 螺纹规格    | 适用电线直径 | 螺纹外径<br>C <sub>1</sub> | 开孔直径      | 螺纹长度<br>C <sub>2</sub> | 螺帽扳手径<br>C <sub>3</sub> | 螺帽扳手径<br>C <sub>4</sub> |
|-------|--------|---------|--------|------------------------|-----------|------------------------|-------------------------|-------------------------|
|       | 螺纹规格   |         |        |                        |           |                        |                         |                         |
| ZIL43 | M12    | M12×1.5 | Ø3~6.5 | 12                     | 12~12.2   | 6                      | 14                      | 14                      |
|       | M16    | M16×1.5 | Ø4~8   | 16                     | 16~16.2   | 7                      | 18                      | 17                      |
|       | M18    | M18×1.5 | Ø6~10  | 18                     | 18~18.2   | 7                      | 20                      | 20                      |
|       | M20    | M20×1.5 | Ø8~12  | 20                     | 20~20.2   | 8                      | 22                      | 22                      |
|       | M22    | M22×1.5 | Ø10~14 | 22                     | 22~22.2   | 8                      | 24                      | 24                      |
|       | M25    | M25×1.5 | Ø13~18 | 25                     | 25~25.2   | 8                      | 30                      | 30                      |
|       | M32    | M32×1.5 | Ø15~22 | 32                     | 32~32.2   | 9                      | 34                      | 34                      |
|       | M40    | M40×1.5 | Ø22~28 | 40                     | 40~40.2   | 10                     | 43                      | 43                      |
|       | M50    | M50×1.5 | Ø32~38 | 50                     | 50~50.2   | 10                     | 58                      | 58                      |
|       | M60    | M60×1.5 | Ø37~44 | 60                     | 60~60.2   | 12                     | 64                      | 64                      |
|       | PG7    | PG7     | Ø3~6.5 | 12.5                   | 12.5~12.7 | 6                      | 14                      | 14                      |
|       | PG9    | PG9     | Ø4~8   | 15.2                   | 15.2~15.4 | 7                      | 17                      | 17                      |
|       | PG11   | PG11    | Ø6~10  | 18.6                   | 18.6~18.8 | 7                      | 20                      | 20                      |
|       | PG13.5 | PG13.5  | Ø8~12  | 20.4                   | 20.4~20.6 | 8                      | 22                      | 22                      |
|       | PG16   | PG16    | Ø10~14 | 22.5                   | 22.5~22.7 | 8                      | 24                      | 24                      |
|       | PG21   | PG21    | Ø13~18 | 28.3                   | 28.3~28.5 | 8                      | 30                      | 30                      |
|       | PG29   | PG29    | Ø18~25 | 37                     | 37~37.2   | 9                      | 40                      | 40                      |
|       | PG36   | PG36    | Ø25~32 | 47                     | 47~47.2   | 10                     | 50                      | 50                      |
|       | PG42   | PG42    | Ø32~38 | 54                     | 54~54.2   | 10                     | 58                      | 58                      |
|       | PG48   | PG48    | Ø37~44 | 59.3                   | 59.3~59.5 | 12                     | 64                      | 64                      |
| PG63  | PG63   | Ø42~52  | 72     | 72~72.2                | 15        | 78                     | 76                      |                         |



请按图示订货

| 型号    |      | 螺纹规格    |
|-------|------|---------|
| 代码    | 螺纹规格 |         |
| ZIL43 | M12  | M12×1.5 |

ZIL43 — M12