

通用铝合金型材

线槽型材

代码	材质	表面处理
ATY05-F	A6063-T5	喷砂氧化

- ① 最大使用长度：5800~5850mm；
整条标准长度：6000~6020mm。
- ② 可定制表面处理。

■ L长度公差



ATY05-F-2040AB
ATY05-F-3030AB
ATY05-F-3060AB
ATY05-F-4040AB
ATY05-F-4080AB

ATY05-F-3030CD ATY05-F-6030CD
ATY05-F-3060CD ATY05-F-6060CD
ATY05-F-4040CD ATY05-F-8040CD
ATY05-F-4080CD ATY05-F-5050CD

ATY05-F-3060GD
ATY05-F-4060GD
ATY05-F-4080GD
ATY05-F-5050GD
ATY05-F-50100GD

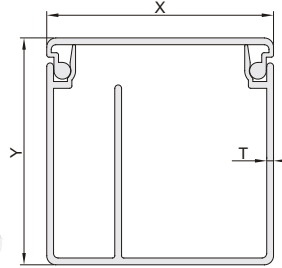
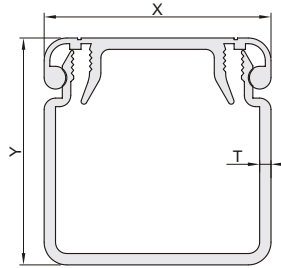
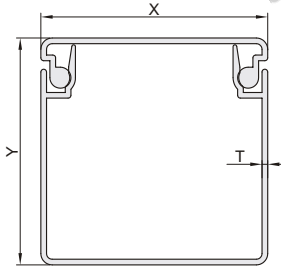

ATY05-F-8080CD
ATY05-F-50100CD

ATY05-F-100100CD

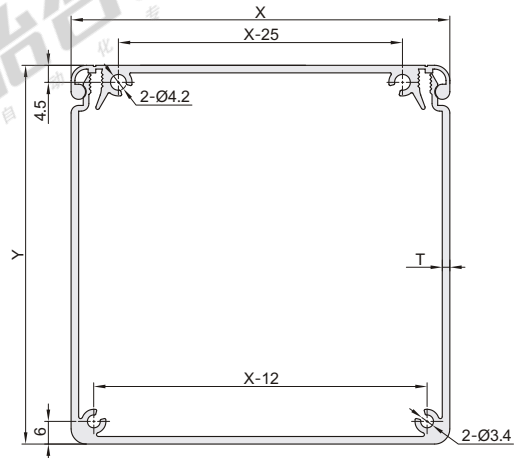
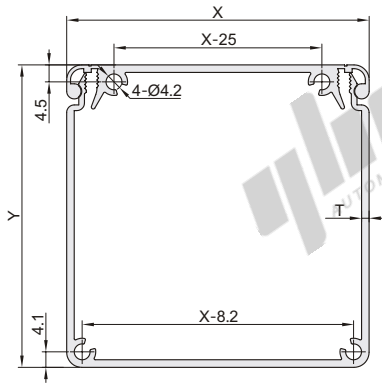

ATY05-F-80160CD

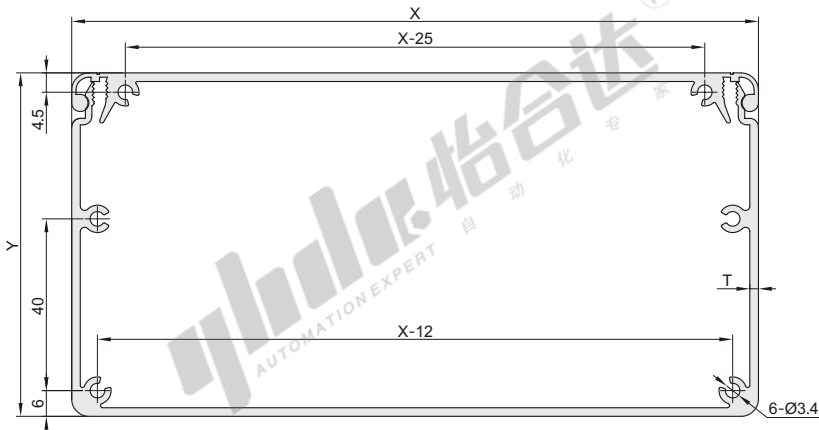

40系列
ATY05-F-40A

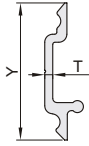

ATY05-F-40C

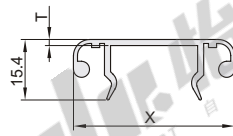

ATY05-F-40D

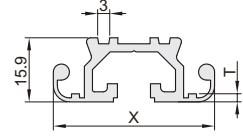

80系列
ATY05-F-80A

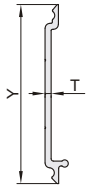

ATY05-F-80C

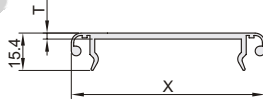

ATY05-F-80D

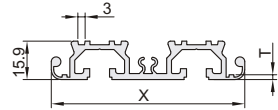

120系列
ATY05-F-120A

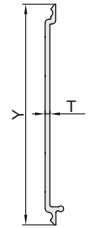

ATY05-F-120C

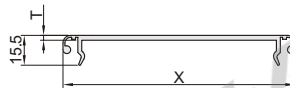

ATY05-F-120D

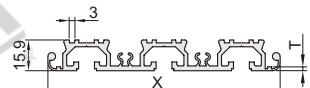

160系列
ATY05-F-160A

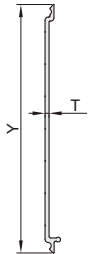

ATY05-F-160C

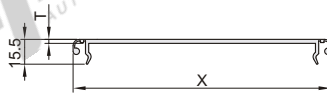

ATY05-F-160D

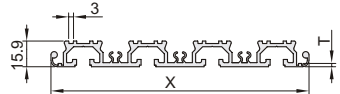

槽口详图

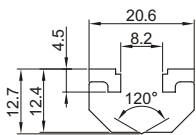

线槽型材组合示意图

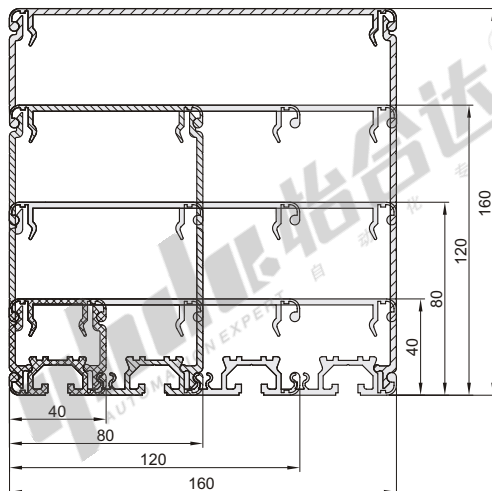

线槽型材组装图

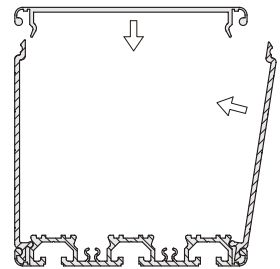

通用铝合金型材

线槽型材

组合线槽示意图

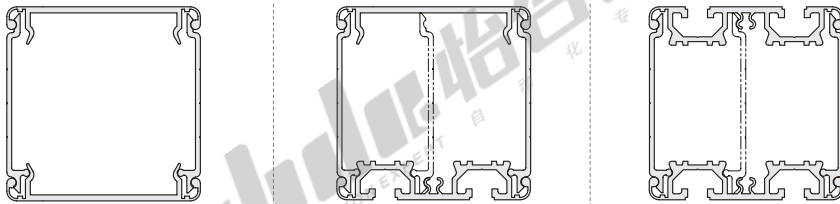

① 因为支撑型材和壁板型材外部尺寸相同，所以可以选择型材相应位置构建不同线槽，用来满足客户的需求。



视角标准：第一视角

代码	型号	L				每米重量Kg/m (理论值)	截面积 (mm ²)
		最小单位0.5	Y	X	T		
ATY05-F	2040AB	50~6000	20	40	1	0.45	163.85
	3030AB		30	30		0.45	163.29
	3060AB		60	60		0.62	223.21
	4040AB		40	40		0.56	203.85
	4080AB		80	80		0.78	283.21
	3030CD		30	30		0.73	263.66
	3060CD		60	60		1.06	383.66
	4040CD		40	40		0.95	343.66
	4080CD		80	80		1.39	504.66
	6030CD		30	30		1.06	383.65
	6060CD		60	60		1.39	503.66
	8040CD		80	40		1.39	503.65
	8080CD		80	80		1.96	711.24
	5050CD		50	50		1.17	423.66
	50100CD		50	100		1.85	671.24
	100100CD		100	100	2.50	907.08	
	80160CD		80	160	3.07	1116.36	
	3060GD		30	60	0.91	331.44	
	4060GD		40	60	1.04	376.44	
	4080GD		40	80	1.21	439.38	
	5050GD		50	50	1.09	395.23	
	50100GD		50	100	1.50	545.22	
	40A		34	—	0.21	75.27	
	40C		—	40	0.35	127.25	
	40D		—	40	0.58	211.20	
	80A		74	—	0.47	171.41	
	80C		—	80	0.64	231.86	
	80D		—	80	1.18	426.27	
	120A		114	—	0.83	300.23	
	120C		—	120	1.00	362.16	
120D	—	120	1.77	641.35			
160A	154	—	1.10	400.08			
160C	—	160	1.27	462.16			
160D	—	160	2.36	856.42			

通用型材系列



型号		L
代码	规格	最小单位0.5
ATY05-F	3030AB	50~6000
	4040CD	

请按图示订货 ATY05-F—3030AB—L800

