

代码	类型	材质			表面处理
		螺杆	底座	橡胶垫	
J-WAC61	万向调节型	无橡胶垫	SUS304	SUS304	—
J-WAC62		带橡胶垫	S45C	S45C	镀锌
J-WAC63		带橡胶垫	SUS304	SUS304	NBR

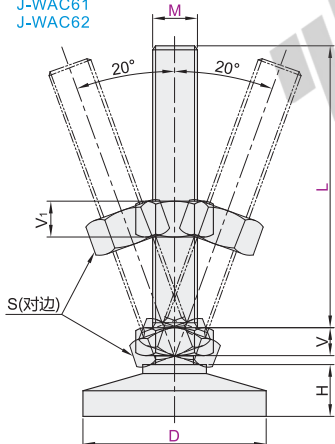

- ① 由于市面上钢材位为5mm一个梯度，且存在公差，因此车制底座公差-2~0mm均为合理范围。
- ② 万向调节脚杯的负载为垂直方向静载值，计算负载值时需要根据实际场景调整安全系数。
- ③ 标准螺杆长度以25mm为一个梯度，可根据客户要求定制长度，需要注意定制长度后，切短的面无表面处理，碳钢会喷漆防锈。

无橡胶垫
J-WAC61
J-WAC62



带橡胶垫
J-WAC63

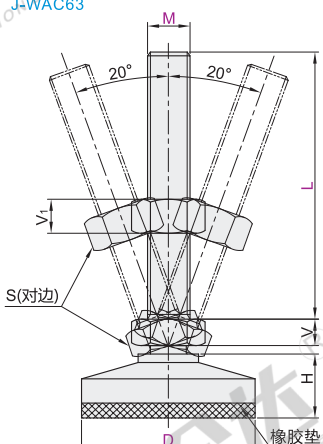

④ 请根据脚杯螺杆尺寸M进行相关配件选择，详见脚杯可选配件汇总。



无橡胶垫

代码	型号	D	M	L	螺距	S	H	V	V ₁	承载(Kg)	参考重量 (Kg/pcs)	
J-WAC61 J-WAC62	60	60	12	125	1.75	19	14.3	8	10	1470	0.36	
				100	2	24					0.44	
			125	2.5				30	0.48			
			200		3	36			0.54			
			100	4				42	0.58			
			125		5	48			0.64			
	150	6	54	1.2								
	20			80	200	3	36	14.9	16	19	4900	1.55
	24	150	3.5		46			19.1			24	24
	30	200		4		48	54	60	66	72		
	J-WAC61	127	127		42						200	4.5
				250		5.6						
300				6.06								

带橡胶垫

代码	型号	D	M	L	螺距	S	H	V	V ₁	承载(Kg)	参考重量 (Kg/pcs)
J-WAC63	100	100	24	150	3	36	43.1	16	19	2000	2.14
				200							2.3
			30	150	3.5	46		24	24	2500	2.78
				200							3.08

可选加工

代码	型号	D	M	L	可选加工代码
J-WAC61	J-WAC62	60	12	125	WS WL BS...
J-WAC61	J-WAC62	60	16	100	

可选配件

代码	型号	D	M	L	可选配件代码
J-WAC61	J-WAC62	60	16	100	JOJP JQ...



请按图示订货

代码	型号	D	M	L
J-WAC61	J-WAC62	60	12	125
J-WAC61	J-WAC62	60	16	100

J-WAC61—D60—M12—L125
J-WAC61—D60—M16—L100—WS



未税价(元)

优惠价

数量	1~9	10~
价格	100%	另行报价



交货期

1

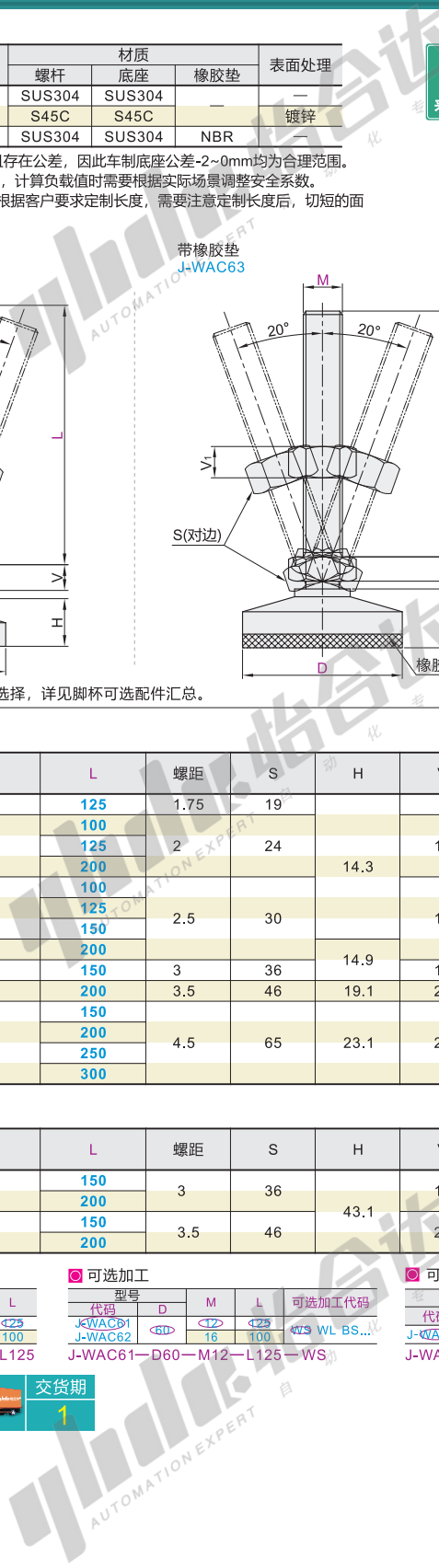



代码	技术说明																																					
WS	螺杆末端加工外四角	<table border="1"> <thead> <tr> <th colspan="3">选型方法 WS</th> </tr> <tr> <th>M</th> <th>n</th> <th>e</th> </tr> </thead> <tbody> <tr> <td>10</td> <td>6</td> <td></td> </tr> <tr> <td>12</td> <td>8</td> <td>10</td> </tr> <tr> <td>14</td> <td></td> <td></td> </tr> <tr> <td>16</td> <td>10</td> <td>12</td> </tr> <tr> <td>20</td> <td>12</td> <td>13.5</td> </tr> <tr> <td>24</td> <td>14</td> <td>15</td> </tr> <tr> <td>30</td> <td>18</td> <td>22</td> </tr> </tbody> </table>	选型方法 WS			M	n	e	10	6		12	8	10	14			16	10	12	20	12	13.5	24	14	15	30	18	22									
	选型方法 WS																																					
M	n	e																																				
10	6																																					
12	8	10																																				
14																																						
16	10	12																																				
20	12	13.5																																				
24	14	15																																				
30	18	22																																				
WL	螺杆末端加工外六角	<table border="1"> <thead> <tr> <th colspan="3">选型方法 WL</th> </tr> <tr> <th>M</th> <th>n1</th> <th>e1</th> </tr> </thead> <tbody> <tr> <td>10</td> <td>6</td> <td></td> </tr> <tr> <td>12</td> <td>8</td> <td>10</td> </tr> <tr> <td>14</td> <td>9</td> <td></td> </tr> <tr> <td>16</td> <td>10</td> <td></td> </tr> <tr> <td>20</td> <td>13</td> <td>14</td> </tr> <tr> <td>24</td> <td>16</td> <td>18</td> </tr> <tr> <td>30</td> <td>20</td> <td>21</td> </tr> </tbody> </table>	选型方法 WL			M	n1	e1	10	6		12	8	10	14	9		16	10		20	13	14	24	16	18	30	20	21									
	选型方法 WL																																					
M	n1	e1																																				
10	6																																					
12	8	10																																				
14	9																																					
16	10																																					
20	13	14																																				
24	16	18																																				
30	20	21																																				
BS	螺杆末端加工扳手槽	<table border="1"> <thead> <tr> <th colspan="4">选型方法 BS</th> </tr> <tr> <th>M</th> <th>n2</th> <th>ee</th> <th>e2</th> </tr> </thead> <tbody> <tr> <td>10</td> <td>8</td> <td>8</td> <td></td> </tr> <tr> <td>12</td> <td>10</td> <td></td> <td></td> </tr> <tr> <td>14</td> <td>12</td> <td></td> <td>12</td> </tr> <tr> <td>16</td> <td>13</td> <td>10</td> <td></td> </tr> <tr> <td>20</td> <td>17</td> <td></td> <td></td> </tr> <tr> <td>24</td> <td>20</td> <td>15</td> <td>18</td> </tr> <tr> <td>30</td> <td>26</td> <td></td> <td></td> </tr> </tbody> </table>	选型方法 BS				M	n2	ee	e2	10	8	8		12	10			14	12		12	16	13	10		20	17			24	20	15	18	30	26		
	选型方法 BS																																					
M	n2	ee	e2																																			
10	8	8																																				
12	10																																					
14	12		12																																			
16	13	10																																				
20	17																																					
24	20	15	18																																			
30	26																																					

代码	技术说明																												
NS	螺杆末端加工内四角	<table border="1"> <thead> <tr> <th colspan="3">选型方法 NS</th> </tr> <tr> <th>M</th> <th>n3</th> <th>e3</th> </tr> </thead> <tbody> <tr> <td>10</td> <td>5</td> <td></td> </tr> <tr> <td>12</td> <td>6</td> <td>10</td> </tr> <tr> <td>14</td> <td></td> <td></td> </tr> <tr> <td>16</td> <td>8</td> <td>12</td> </tr> <tr> <td>20</td> <td>10</td> <td>13.5</td> </tr> <tr> <td>24</td> <td>10</td> <td>15</td> </tr> <tr> <td>30</td> <td></td> <td>20</td> </tr> </tbody> </table>	选型方法 NS			M	n3	e3	10	5		12	6	10	14			16	8	12	20	10	13.5	24	10	15	30		20
	选型方法 NS																												
M	n3	e3																											
10	5																												
12	6	10																											
14																													
16	8	12																											
20	10	13.5																											
24	10	15																											
30		20																											
NL	螺杆末端加工内六角	<table border="1"> <thead> <tr> <th colspan="3">选型方法 NL</th> </tr> <tr> <th>M</th> <th>n4</th> <th>e4</th> </tr> </thead> <tbody> <tr> <td>10</td> <td>4</td> <td>5</td> </tr> <tr> <td>12</td> <td>6</td> <td>8</td> </tr> <tr> <td>14</td> <td>8</td> <td></td> </tr> <tr> <td>16</td> <td>10</td> <td></td> </tr> <tr> <td>20</td> <td>10</td> <td>12</td> </tr> <tr> <td>24</td> <td>12</td> <td>15</td> </tr> <tr> <td>30</td> <td>16</td> <td>18</td> </tr> </tbody> </table>	选型方法 NL			M	n4	e4	10	4	5	12	6	8	14	8		16	10		20	10	12	24	12	15	30	16	18
	选型方法 NL																												
M	n4	e4																											
10	4	5																											
12	6	8																											
14	8																												
16	10																												
20	10	12																											
24	12	15																											
30	16	18																											
MS	铆死底座与螺杆	<table border="1"> <thead> <tr> <th colspan="2">选型方法 MS</th> </tr> </thead> <tbody> <tr> <td>铆死状态</td> <td>正常状态</td> </tr> </tbody> </table>	选型方法 MS		铆死状态	正常状态																							
	选型方法 MS																												
铆死状态	正常状态																												
<p>① 底座与螺杆铆死，可以提高底座和螺杆的连接刚度，但是底座与螺杆无法相对转动；</p> <p>② 铆死后调节是底座也会随螺杆一起转动。</p> <p>③ 不适用于万向类型、橡胶底座型和非铆接组装的脚杯。</p>																													

- ① 请根据脚杯螺杆尺寸M进行扳手位加工参数的选择；
- ② 扳手位加工部位不带镀层，有防锈漆；
- ③ 工具可根据不同扳手位加工类型进行选择，可选用开口扳手、活动扳手、内六角扳手、内六角扳手等。



可选配件	代码	技术说明	适用脚杯	推荐型材/脚轮	注意事项/使用示例																																
调整脚底座	DA	<p>M42 Tr42</p> <p>M52/60 Tr52/60</p>	<p>选型方法 DA</p> <table border="1"> <tr><th>类型</th><th>材质</th><th>M</th><th>D</th><th>D1</th><th>D2</th><th>L</th><th>H</th></tr> <tr><td>公制</td><td>M42x4.5</td><td>97</td><td>77</td><td>60</td><td>22</td><td>18</td><td></td></tr> <tr><td>螺纹</td><td>SUS304</td><td>M52x5</td><td>107</td><td>87</td><td>71</td><td>30</td><td>20</td></tr> <tr><td></td><td>M60x5.5</td><td>117</td><td>97</td><td>80</td><td>40</td><td>20</td><td></td></tr> </table> <p>① M42包含配件: 螺母AHQ22-308-M8, 数量4PCS; 螺钉AID31-M8-L12, 数量4PCS。</p> <p>② M52/M60包含配件: 螺母AHQ22-308-M8, 数量6PCS; 螺钉AID31-M8-L12, 数量6PCS。</p>	类型	材质	M	D	D1	D2	L	H	公制	M42x4.5	97	77	60	22	18		螺纹	SUS304	M52x5	107	87	71	30	20		M60x5.5	117	97	80	40	20		J-WAC61 J-WAC71 WAM61	<p>① 请根据脚杯螺杆尺寸M进行相关配件选择, 梯形螺纹公称直径M用Tr表示。</p> <p>② 仅提供脚杯及相关配件选购, 型材具体适用型号请咨询型材产品中心。螺母、螺钉如选用其他型号请咨询型材产品中心。</p>
	类型	材质	M	D	D1	D2	L	H																													
公制	M42x4.5	97	77	60	22	18																															
螺纹	SUS304	M52x5	107	87	71	30	20																														
	M60x5.5	117	97	80	40	20																															
DB	<p>4-Ø9通孔 沉孔Ø14深8.6</p> <p>6-Ø9通孔 沉孔Ø14深8.6</p>	<p>选型方法 DB</p> <table border="1"> <tr><th>类型</th><th>材质</th><th>M</th><th>D</th><th>D1</th><th>D2</th><th>L</th><th>H</th></tr> <tr><td>梯形</td><td>Tr42x6</td><td>97</td><td>77</td><td>60</td><td>22</td><td>18</td><td></td></tr> <tr><td>螺纹</td><td>SUS304</td><td>Tr52x7</td><td>107</td><td>87</td><td>71</td><td>30</td><td>20</td></tr> <tr><td></td><td>Tr60x8</td><td>117</td><td>97</td><td>80</td><td>40</td><td>20</td><td></td></tr> </table> <p>① Tr42包含配件: 螺母AHQ22-308-M8, 数量4PCS; 螺钉AID31-M8-L12, 数量4PCS。</p> <p>② Tr52/Tr60包含配件: 螺母AHQ22-308-M8, 数量6PCS; 螺钉AID31-M8-L12, 数量6PCS。</p>	类型	材质	M	D	D1	D2	L	H	梯形	Tr42x6	97	77	60	22	18		螺纹	SUS304	Tr52x7	107	87	71	30	20		Tr60x8	117	97	80	40	20		J-WAC72	<p>① 请根据脚杯螺杆尺寸M进行相关配件选择, 梯形螺纹公称直径M用Tr表示。</p> <p>② 仅提供脚杯及相关配件选购, 型材具体适用型号请咨询型材产品中心。螺母、螺钉如选用其他型号请咨询型材产品中心。</p>	
类型	材质	M	D	D1	D2	L	H																														
梯形	Tr42x6	97	77	60	22	18																															
螺纹	SUS304	Tr52x7	107	87	71	30	20																														
	Tr60x8	117	97	80	40	20																															
脚杯连接板	JO		<p>选型方法 JO</p> <table border="1"> <tr><th>材质</th><th>表面处理</th><th>M(适用螺杆)</th></tr> <tr><td>S45C</td><td>烤漆(黑色)</td><td>16</td></tr> </table> <p>① 包含配件: 螺母AHQ22-308-M8, 数量4PCS; 螺钉AID31-M8-L16, 数量4PCS。</p>	材质	表面处理	M(适用螺杆)	S45C	烤漆(黑色)	16	<p>J-WAC61 J-WAC71 WAM61</p> <p>J-WAC72</p> <p>WAC3150系列 WAC6168系列 WAK0102系列 WAK21系列 WALD0122系列 WAD0118/19系列 WAD31516系列 WAD27586系列 WAD0101系列 WAD0102系列 WAD0101系列 E-WAG0181系列 E-WAB0102系列 E-WAD0121系列 E-WAD2651系列 E-WAD8系列 E-WAC5153系列 E-WAR1141系列 E-BZ01 E-BZ01系列 E-WAL31系列 WAC0102/31系列 J-WAC61系列</p> <p>型材: AGB06-6630R AGB06-3060Y AGB06-6080Y等</p> <p>脚轮: CEL31等</p>	<p>① 请根据脚杯螺杆尺寸M进行相关配件选择。</p> <p>② 仅提供脚杯及相关配件选购, 型材具体适用型号请咨询型材产品中心。螺母、螺钉如选用其他型号请咨询型材产品中心。</p> <p>③ 脚杯、脚轮一起使用时, 脚杯底座直径须≤60mm, 否则会发生干涉。</p> <p>④ 适用脚杯代码后有“系列”二字时, 指目录书同一页上同一类型的所有脚杯代码均适用。</p>																										
	材质	表面处理	M(适用螺杆)																																		
	S45C	烤漆(黑色)	16																																		
	JP	<p>4-Ø8.5×13.5通孔 沉孔Ø14×19深9</p>	<p>选型方法 JP</p> <table border="1"> <tr><th>材质</th><th>表面处理</th><th>M(适用螺杆)</th></tr> <tr><td>S45C</td><td>烤漆(白色)</td><td>16</td></tr> </table> <p>① 包含配件: 螺母AHQ22-308-M8, 数量4PCS; 螺钉AID31-M8-L16, 数量4PCS。</p>	材质	表面处理	M(适用螺杆)	S45C	烤漆(白色)	16																												
	材质	表面处理	M(适用螺杆)																																		
	S45C	烤漆(白色)	16																																		
JQ		<p>选型方法 JQ</p> <table border="1"> <tr><th>材质</th><th>表面处理</th><th>M(适用螺杆)</th></tr> <tr><td>S45C</td><td>烤漆(黑色)</td><td>16</td></tr> </table> <p>① 包含配件: 螺母AHQ22-308-M8, 数量4PCS; 螺钉AID31-M8-L16, 数量4PCS。</p>	材质	表面处理	M(适用螺杆)	S45C	烤漆(黑色)	16																													
材质	表面处理	M(适用螺杆)																																			
S45C	烤漆(黑色)	16																																			
JR	<p>4-Ø8.5×13.5通孔 沉孔Ø14×19深9</p>	<p>选型方法 JR</p> <table border="1"> <tr><th>材质</th><th>表面处理</th><th>M(适用螺杆)</th></tr> <tr><td>S45C</td><td>烤漆(白色)</td><td>16</td></tr> </table> <p>① 包含配件: 螺母AHQ22-308-M8, 数量4PCS; 螺钉AID31-M8-L16, 数量4PCS。</p>	材质	表面处理	M(适用螺杆)	S45C	烤漆(白色)	16																													
材质	表面处理	M(适用螺杆)																																			
S45C	烤漆(白色)	16																																			
JS		<p>选型方法 JS</p> <table border="1"> <tr><th>材质</th><th>表面处理</th><th>M(适用螺杆)</th></tr> <tr><td>S45C</td><td>烤漆(黑色)</td><td>16</td></tr> </table> <p>① 包含配件: 螺母AHQ22-308-M8, 数量4PCS; 螺钉AID31-M8-L16, 数量4PCS。</p>	材质	表面处理	M(适用螺杆)	S45C	烤漆(黑色)	16																													
材质	表面处理	M(适用螺杆)																																			
S45C	烤漆(黑色)	16																																			
JT	<p>4-Ø8.3通孔 沉孔Ø14深9</p>	<p>选型方法 JT</p> <table border="1"> <tr><th>材质</th><th>表面处理</th><th>M(适用螺杆)</th></tr> <tr><td>S45C</td><td>烤漆(白色)</td><td>16</td></tr> </table> <p>① 包含配件: 螺母AHQ22-308-M8, 数量4PCS; 螺钉AID31-M8-L16, 数量4PCS。</p>	材质	表面处理	M(适用螺杆)	S45C	烤漆(白色)	16																													
材质	表面处理	M(适用螺杆)																																			
S45C	烤漆(白色)	16																																			
JU		<p>选型方法 JU</p> <table border="1"> <tr><th>材质</th><th>表面处理</th><th>M(适用螺杆)</th></tr> <tr><td>S45C</td><td>烤漆(黑色)</td><td>16</td></tr> </table> <p>① 包含配件: 螺母AHQ22-308-M8, 数量4PCS; 螺钉AID31-M8-L16, 数量4PCS。</p>	材质	表面处理	M(适用螺杆)	S45C	烤漆(黑色)	16																													
材质	表面处理	M(适用螺杆)																																			
S45C	烤漆(黑色)	16																																			
JV	<p>4-Ø8.3通孔 沉孔Ø14深9</p>	<p>选型方法 JV</p> <table border="1"> <tr><th>材质</th><th>表面处理</th><th>M(适用螺杆)</th></tr> <tr><td>S45C</td><td>烤漆(白色)</td><td>16</td></tr> </table> <p>① 包含配件: 螺母AHQ22-308-M8, 数量4PCS; 螺钉AID31-M8-L16, 数量4PCS。</p>	材质	表面处理	M(适用螺杆)	S45C	烤漆(白色)	16																													
材质	表面处理	M(适用螺杆)																																			
S45C	烤漆(白色)	16																																			

① 可根据客户需求进行相关连接件的定制。