

代码	类型	材质				表面处理
		支架	销	垫圈	挡圈	
FHJ21	氮气弹簧 安装用支架	SUS430	Q235	SPHC	SK5	铬酸盐光泽处理
FHJ22		SPHC	SWRCH	—	—	
FHJ26		SUS304	SUS304	—	SUS304	

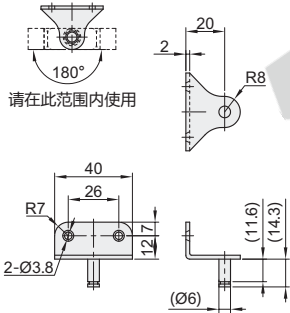

FHJ21
规格: 6A



附件
①E型挡圈



②垫圈

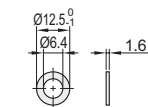

FHJ22
规格: 8A

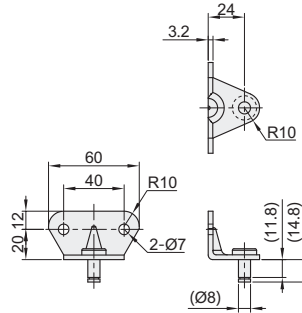

附件
①E型挡圈



②垫圈

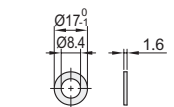

FHJ22
规格: 8C

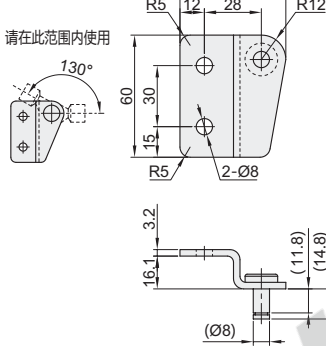

附件
①E型挡圈



②垫圈

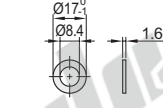

FHJ22
规格: 8B

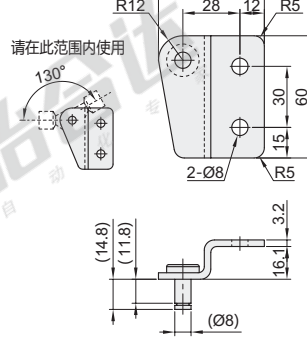

附件
①E型挡圈



②垫圈

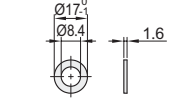

FHJ22
规格: 8D

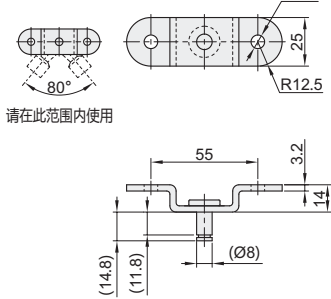

附件
①E型挡圈



②垫圈

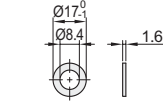

FHJ22
规格: 8E

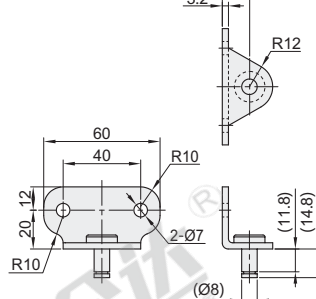

附件
①E型挡圈



②垫圈

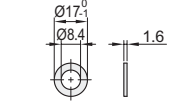

视角标准: 第一视角

FHJ26
规格: 8F

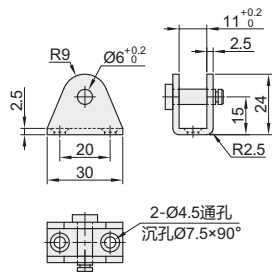

附件
①E型挡圈



②铰链销



型号		附件	重量 (g)
代码	规格		
FHJ21	6A		20
	8A		
	8B	1个垫圈	
	8C	1个挡圈	
FHJ22	8D		58
	8E		
	8F	1个铰链销 1个挡圈	
FHJ26	8F	1个铰链销 1个挡圈	34

请按图示订货

未报价元

交货期
3