

# 工厂设备配管用接头

HYBRID TOYOCONNECTOR®

种类

圆盖螺母、管夹型

螺丝

## TOYOCONNECTOR TC3-PB型规格 RoHS2

接头外观	接头型号	适用胶管		螺纹规格	尺寸(mm)			重量	包装单位
		内径 mm	型号		L	φd1	HEX 1		
 (HYBRID) 室内专用	TC3-PB 9-R3/8	9	HPT,TR,HTR,ST,TSG,TS,TG,HTD,TFB	R3/8	51.0	7.0	27	54	20
	TC3-PB 12-R1/2	12		R1/2	55.0	10.0	30	81	20
	TC3-PB 15-R1/2	15	HPT,TR,HTR,ST,TSG,TS,TG,HTD,TFB,HTF,TGF	R1/2	58.0	13.0	36	91	20
	TC3-PB 19-R3/4	19		R3/4	62.5	17.0	41	125	10
	TC3-PB25-R1	25	HPT,TR,HTR,ST,TSG,TS,TG,HTD,TFB,HTF,TFS,TGF	R1	68.5	22.5	50	200	10

材质 / 接头、圆盖螺母内环：黄铜；圆盖螺母：尼龙；螺纹、套管：聚甲醛

※ 符合 RoHS2 修正规制

## TOYOCONNECTOR TC3-PC型规格 RoHS2

旧型号 TCP(TCP-ST)

接头外观	接头型号	适用胶管		螺纹规格	尺寸(mm)			重量	包装单位
		内径 mm	型号		L	φd1	HEX 1		
 (HYBRID) 室内专用	TC3-PC 9-R3/8	9	HPT,TR,HTR,ST,TSG,TS,HTD,TFB,EC,FF	R3/8	51.0	5.5	27	26	20
	TC3-PC 12-R1/2	12	HPT,TR,HTR,ST,TSG,TS,HTD,TFB,EC,FF,FFY	R1/2	55.0	8.0	30	32	20
	TC3-PC 15-R1/2	15	HPT,TR,HTR,ST,TSG,TS,HTD,TFB,HTF,EC,FF,FFY,FFS	R1/2	58.0	11.0	36	48	20
	TC3-PC 19-R3/4	19	HPT,TR,HTR,ST,TSG,TS,HTD,TFB,HTF,EC,FF,FFY,FFYS,FFS	R3/4	62.5	15.0	41	63	10
	TC3-PC25-R1	25	HPT,TR,HTR,ST,TSG,TS,HTD,TFB,HTF,TFS,EC,ECS,FF,FFY,FFYS,FFS	R1	68.5	20.0	50	97	10

材质 / 管接头：PPSU树脂、圆盖螺母：尼龙、螺丝：SPS树脂、密封圈：聚丙烯

※ 符合 RoHS2 修正规制

## TOYOCONNECTOR TC3-SS型规格(硅胶胶管系列专用) RoHS2

旧型号 TCSBS、TCSS

接头外观	接头型号	适用胶管		螺纹规格	尺寸(mm)				重量	包装单位
		内径 mm	型号		L	φd1	HEX 1	HEX 2		
 (HYBRID)	TC3-SS 9-R3/8	9	TSI,TSISTM,TSITH	R3/8	48.0	6.9	28	24.2	133	20
	TC3-SS 12-R1/2	12	TSI,HTSI,TSIP,TSISTM,TSITH	R1/2	53.0	10.1	32	27.0	178	20
	TC3-SS 15-R1/2	15		R1/2	55.0	13.3	36	30.8	217	20
	TC3-SS 19-R3/4	19	TSI,HTSI,TSIS-PH,TSIP,TSISTM,	R3/4	59.5	16.9	41	35.8	290	10
	TC3-SS25-R1	25	TSITH	R1	66.0	22.8	50	43.8	438	10

材质 / 圆盖螺母：SCS13(相当于 SUS304)；接头：SCS16(相当于 SUS316L)；套管：PVDF

※ 符合 RoHS2 修正规制

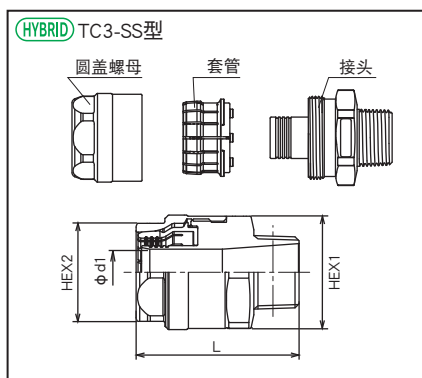
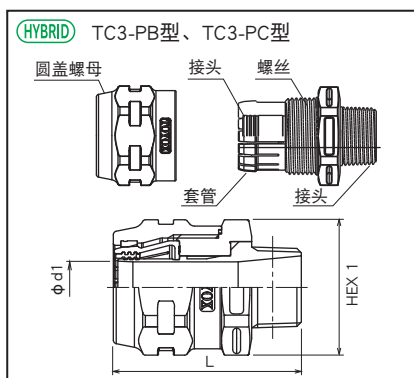

### ■ 安装工具

在紧固上，请使用“活动扳手”或者“电机扳手”。  
请不要使用“管钳”。会损伤螺母。



活动扳手

电机扳手



管钳

### ■ 更换用TC3-PB套管

更换零件	型号	包装单位
	TC3-PB 9-S	10
	TC3-PB12-S	10
	TC3-PB15-S	10
	TC3-PB19-S	10
	TC3-PB25-S	10

材质 / 套管：聚甲醛树脂

### ■ 更换用TC3-SS套管

更换零件	型号	包装单位
	TC3-SS 9-S	20
	TC3-SS12-S	20
	TC3-SS15-S	20
	TC3-SS19-S	10
	TC3-SS25-S	10

材质 / 套管：PVDF

· 由于印刷工艺上的差异，登载产品的颜色可能与实物有所不同。  
· 若因产品改进而变更规格，恕不另行通知。

TOYOCONNECTOR 螺纹

接头

圆盖螺母、管夹型

扣压

■ TOYOCONNECTOR TC6-B型(管夹型)规格 RoHS2

旧型号 TCB(TCB-ST)

接头外观	接头型号	适用胶管		螺纹规格	尺寸(mm)					重量	包装单位
		内径 mm	型号		L	φ d1	HEX 1	HEX 2	F		
	TC6-B32-R1-1/4	32	HPT,TR,ST,TS,TG,TFB,TFS,TGF,EC,ECS	R1-1/4	86.0	28.5	46	6	81	540	4
	TC6-B38-R1-1/2	38		R1-1/2	93.0	34.0	55	6	88	720	4
	TC6-B50-R2	50		R2	110.0	44.0	70	8	106	1250	2

材质 / 接头: 黄铜; 管夹: SCS14(相当于SUS316); 橡胶盖: NBR; 螺栓: SUSXM7(相当于SUS304) ※符合RoHS2修正规制  
 衬垫、垫圈(仅限TC6-B50、TC6-S50规格): 聚甲醛; 螺栓螺纹部的润滑剂: NSF“H1”中注册的润滑脂(极压润滑脂)

■ TOYOCONNECTOR TC6-S型(管夹型)规格 RoHS2

接头外观	接头型号	适用胶管		螺纹规格	尺寸(mm)					重量	包装单位
		内径 mm	型号		L	φ d1	HEX 1	HEX 2	F		
	TC6-S32-R1-1/4	32	HPT,TR,ST,TS,TG,TFB,TFS,TGF,EC,ECS,FF,FFS	R1-1/4	86.0	27.0	46	6	81	550	4
	TC6-S38-R1-1/2	38		R1-1/2	93.0	32.0	55	6	88	745	4
	TC6-S50-R2	50		R2	110.0	43.0	70	8	106	1240	2

材质 / 接头: SCS13(相当于SUS304); 管夹: SCS14(相当于SUS316); 橡胶盖: NBR; 螺栓: SUSXM7(相当于SUS304) ※符合RoHS2修正规制  
 衬垫、垫圈(仅限TC6-B50、TC6-S50规格): 聚甲醛; 螺栓螺纹部的润滑剂: NSF“H1”中注册的润滑脂(极压润滑脂)

HYBRID TC6-B型、TC6-S型

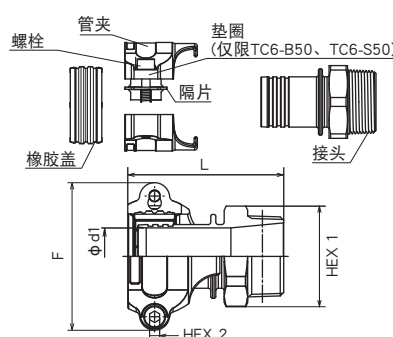

TOYOCONNECTOR 型号	管接头六角部对边(mm)	螺栓六角孔尺寸(mm)
TC6-B32, TC6-S32	46	6
TC6-B38, TC6-S38	55	6
TC6-B50, TC6-S50	70	8

■ 安装工具

在螺栓的紧固上, 请使用长度180mm以上(TC6-S50为200mm以上)的“六角扳手”。



■ 更换用TC6-B、TC6-S通用橡胶盖

更换零件	型号	包装单位
	TC6-32-G	4
	TC6-38-G	4
	TC6-50-G	2

材质 / 橡胶密封垫圈: NBR

























■ 更换用TC6-B、TC6-S通用管夹套件

更换零件	型号	包装单位
	TC6-32-CBSS	1
	TC6-38-CBSS	1
	TC6-50-CBSS	1

材质 / 管夹: SCS14(相当于SUS316)  
 衬垫、垫圈(仅限50规格): 聚甲醛  
 螺栓: SUSXM7(相当于SUS304);  
 螺栓螺纹部的润滑剂: NSF“H1”中注册的润滑脂(极压润滑脂)

- ⚠ TOYOCONNECTOR为TOYOX胶管专用的胶管接头。如果用于连接其他公司胶管以及不适用的胶管, 将无法充分发挥并保持原有的性能, 本公司对此不作任何保证。
- ⚠ 接头的螺纹部有高低差, 因此请勿用于卫生级不锈钢配管(食品等)。
- ⚠ 请务必确认P.186、187、189、191的“安全使用注意事项”。
- ⚠ 与胶管配套时的使用温度范围及使用压力范围以胶管性能为准。但TC3-SS型的TOYOSILICONE Hose、TOYOSILICONE-S-PH、TOYOSILICONE THERMO Hose140请在140℃以下, HYBRID TOYOSILICONE Hose请在130℃以下, TOYOSILICONE THERMO Hose请在120℃以下, TOYOSILICONE-P Hose请在100℃以下的温度范围内使用。请通过适用胶管的规格表或主页进行确认。

■ 适用胶管刊载页

TSI	HTSI	TSIS-PH	TSIP	TSISM	TSITH	FF	FFY	FFYS	FFS	EC	ECS
											
▶P.55	▶P.57	▶P.58	▶P.59	▶P.61	▶P.62	▶P.65	▶P.66	▶P.67	▶P.69	▶P.70	▶P.70
TFB	HTF	TFS	TGF	TR	HTR	HPT	ST	TS	TG	TSG	HTD
											
▶P.71	▶P.71	▶P.72	▶P.73	▶P.76	▶P.77	▶P.78	▶P.79	▶P.80	▶P.81	▶P.82	▶P.83