

# 加强筋

## 通孔型 直角型



代码	类型	材质		表面处理
		国标	相当	
ZGB25	直角型 通孔型	6061	A6061	—
ZGB21				发黑
ZGB22				镀硬铬
ZGB26				无电解镀镍
ZGB27				—
ZGB23				本色阳极氧化
ZGB24				黑色阳极氧化
ZGB28	0Cr18Ni9	SUS304	—	
ZGB61	直角型 孔位指定型	6061	A6061	—
ZGB62				发黑
ZGB63				无电解镀镍
ZGB64				—
ZGB65				本色阳极氧化
ZGB66				黑色阳极氧化
ZGB67				0Cr18Ni9

① 当产品材质为S45C且无表面处理，使用时需进行防锈处理。

### 孔位固定型

ZGB21/22  
ZGB23/24  
ZGB25/26  
ZGB27/28

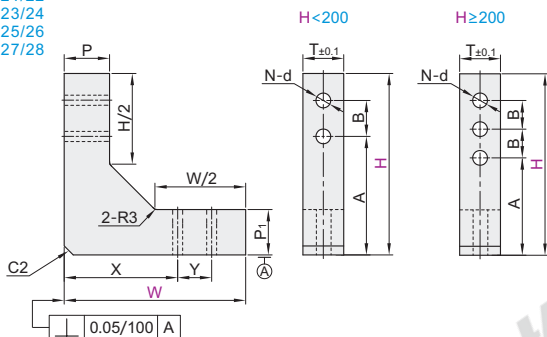

### 孔位指定型

ZGB61/62  
ZGB63/64  
ZGB65/66  
ZGB67

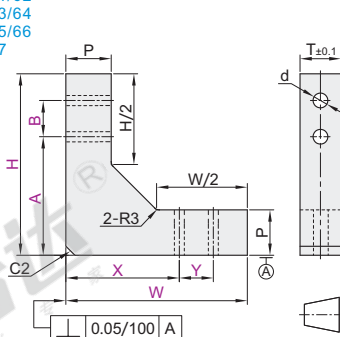

视角标准：第一视角

### 孔位固定型

型号	W	H	T			d	X	Y	A	B	P	P <sub>1</sub>	N										
			S45C	A6061	SUS304																		
ZGB21 ZGB22 ZGB23 ZGB24 ZGB25 ZGB26 ZGB27 ZGB28	30	30	12	10	5.5	20	—	—	—	—	—	—	2										
		50												—	—	—	—	—	—	—	—		
		80																				8	8
	ZGB61 ZGB62 ZGB63 ZGB64 ZGB65 ZGB66 ZGB67	30	30	12	10	5.5	35	—	—	—	—	—	—	2									
			50												—	—	—	—	—	—	—	—	
			80																				12
		ZGB21 ZGB22 ZGB23 ZGB24 ZGB25 ZGB26 ZGB27 ZGB28	50	50	12	10	5.5	35	—	—	—	—	—	—	2								
				80												—	—	—	—	—	—	—	—
				100																			
			ZGB61 ZGB62 ZGB63 ZGB64 ZGB65 ZGB66 ZGB67	50	50	12	10	5.5	35	—	—	—	—	—	—	2							
80					—												—	—	—	—	—	—	—
100																							
ZGB21 ZGB22 ZGB23 ZGB24 ZGB25 ZGB26 ZGB27 ZGB28				80	80	12	12	6.5	50	15	90	30	30	—	—	4							
	100				—												—	—	—	—	—	—	—
	150																						
	ZGB61 ZGB62 ZGB63 ZGB64 ZGB65 ZGB66 ZGB67			80	80	12	12	6.5	50	15	90	30	30	—	—	4							
		100			—												—	—	—	—	—	—	—
		150																					
		ZGB21 ZGB22 ZGB23 ZGB24 ZGB25 ZGB26 ZGB27 ZGB28		100	100	12	12	6.5	60	20	140	20	—	—	—	5							
			150		—												—	—	—	—	—	—	—
			200																				
			ZGB61 ZGB62 ZGB63 ZGB64 ZGB65 ZGB66 ZGB67	100	100	12	12	6.5	60	20	140	20	—	—	—	5							
150					—												—	—	—	—	—	—	—
200																							
ZGB21 ZGB22 ZGB23 ZGB24 ZGB25 ZGB26 ZGB27 ZGB28				150	150	12	12	6.5	90	30	140	20	—	—	—	4							
	200				—												—	—	—	—	—	—	—
	250																						
	ZGB61 ZGB62 ZGB63 ZGB64 ZGB65 ZGB66 ZGB67			150	150	12	12	6.5	90	30	140	20	—	—	—	4							
		200			—												—	—	—	—	—	—	—
		250																					
		ZGB21 ZGB22 ZGB23 ZGB24 ZGB25 ZGB26 ZGB27 ZGB28		300	300	12	12	6.5	180	40	180	40	—	—	—	5							
			300A		—												—	—	—	—	—	—	—
			300																				
			ZGB61 ZGB62 ZGB63 ZGB64 ZGB65 ZGB66 ZGB67	300	300	12	12	6.5	180	40	180	40	—	—	—	5							
300A					—												—	—	—	—	—	—	—
300																							
ZGB21 ZGB22 ZGB23 ZGB24 ZGB25 ZGB26 ZGB27 ZGB28				300	300	12	12	6.5	180	40	180	40	—	—	—	5							
	300A				—												—	—	—	—	—	—	—
	300																						
	ZGB61 ZGB62 ZGB63 ZGB64 ZGB65 ZGB66 ZGB67			300	300	12	12	6.5	180	40	180	40	—	—	—	5							
		300A			—												—	—	—	—	—	—	—
		300																					

### 孔位指定型

型号	W	H	最小单位1				d	T			P						
			X	Y	A	B		S45C	A6061	SUS304							
ZGB61 ZGB62 ZGB63 ZGB64 ZGB65 ZGB66 ZGB67	30	30	22~24	—	—	—	3.5	12	10	—	8						
		50										—	—	—	—	—	—
		80															
ZGB61 ZGB62 ZGB63 ZGB64 ZGB65 ZGB66 ZGB67	50	50	32~44	—	—	—	5.5	12	12	—	20						
		80										—	—	—	—	—	—
		100															
ZGB61 ZGB62 ZGB63 ZGB64 ZGB65 ZGB66 ZGB67	100	100	60~76	—	—	—	9	12	12	—	25						
		150										—	—	—	—	—	—
		150															

- ① W=30/50时，底部安装面有1个安装孔，因此无需指定Y尺寸。
- ② H=30/50时，侧面安装面有1个安装孔，因此无需指定B尺寸。
- ③ Y尺寸、B尺寸指定为0时，底部和侧面安装面可开设1个安装孔。

### 通孔型(孔位固定型)

型号		
代码	W	H
ZGB21	30	30
ZGB22	30	50

请按图示订货

ZGB21—W30—H50

### 通孔型(孔位指定型)

型号						
代码	W	H	X	Y	A	B
ZGB61	30	30	20~24	—	A <sub>2</sub> (H/2)+6	—
ZGB62	30	50	20~24	—	A <sub>2</sub> (H/2)+6	—

ZGB61—W30—H50—X20—A30—d4.5

优惠价

数量 1~9 10~

价格 100% 另行报价

未税价(元)

交货期

7

角座  
加强筋  
A12