

加强筋

螺纹孔型 直角型



代码	类型	材质		表面处理
		国标	相当	
ZGB45	直角型 螺纹孔型	45	S45C	—
ZGB41				发黑
ZGB42				无电解镀锌
ZGB46		6061	A6061	—
ZGB43				本色阳极氧化
ZGB44				黑色阳极氧化
ZGB47				—
	0Cr18Ni9	SUS304	—	

① 当产品材质为S45C且无表面处理，使用时需进行防锈处理。

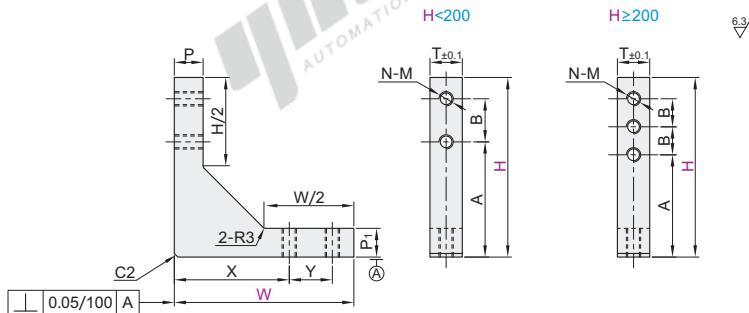

视角标准：第一视角

型号 代码	W	H	T		X	Y	A	B	P	P ₁	M	N	
			S45C	A6061/SUS304									
ZGB45 ZGB41 ZGB42 ZGB46 ZGB43 ZGB44 ZGB47	30	30	12	10	20	—	20	—	8	8	5	2	
		50					35	15					12
		80					60						
	40	40	12	10	30	—	25	—	10	10	5	3	
		50					35						
		60					40	10					
		80					50	15					
		100					60	20					
		50					50	12					10
	60		40	10									
	80		50	15									
	100		60	20									
150A	90		30	17	20	8							
60	60	12	12	40	10	40	10	15	15	5	4		
	80					50	15						
	100					60	20						
ZGB45 ZGB41 ZGB42 ZGB46 ZGB43 ZGB44 ZGB47	80	80	12	12	50	15	50	15	20	20	6	4	
		100					60	20					8
		150					90	30					
	150A	16	16	50	15	90	30	30	6	8			
	200	12	12								140	20	25
	200A	16	16	160	30	25	25	6	8				
	250	12	12							60	20	140	20
	250A	16	16	160	30	180	40	6	8				
	300	12	12							90	30	90	30
	300A	16	16	140	20	140	20	40	40				
	150	12	12							90	30	160	30
	150A	16	16	160	30	180	40	6	8				
200	12	12	90							30	140	20	40
200A	16	16		160	30	180	40	6	8				
250	12	12	90							30	160	30	40
250A	16	16		160	30	180	40	6	8				
300	12	12	90							30	160	30	40
300A	16	16		160	30	180	40	6	8				

支撑类
角座·加强筋
A12



型号		H
代码	W	
ZGB41	30	30
ZGB42	30	50

ZGB41—W30—H50



优惠价	数量	1~9	10~
●	价格	100%	另行报价

交货期	7
●	7