

# 张紧机构

- 螺纹调整型
- 单弹簧调整型/双弹簧调整型

代码	类型	材质				表面处理			
		主体	滑块	轴	调节螺栓	主体	滑块	轴	调节螺栓
ZCL61	螺纹调整型		Q235	S45C		发黑	镀硬铬		
ZCL62	单弹簧调整型	SUS304	树脂(黑色)	S45C		发黑			
ZCL63	双弹簧调整型		SUS304	SUS304					
ZCL64									



螺纹调整型  
ZCL61

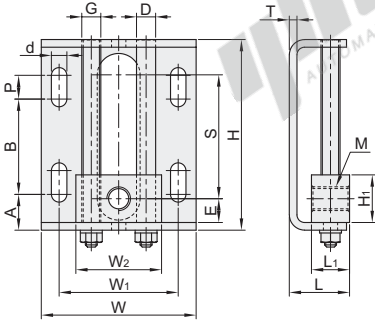

单弹簧调整型  
ZCL62

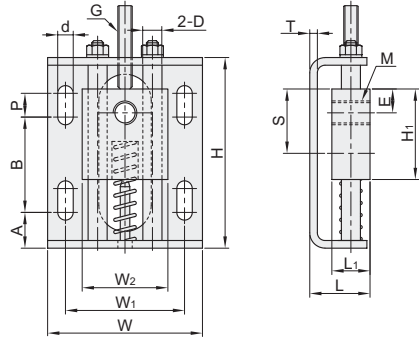

双弹簧调整型  
ZCL63/64  
W: 80

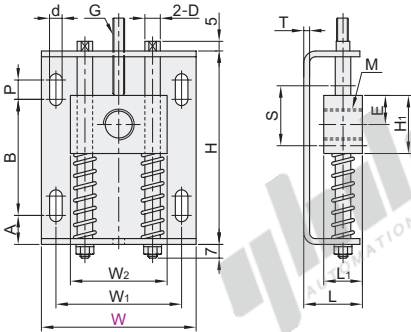

ZCL64  
W: 80A

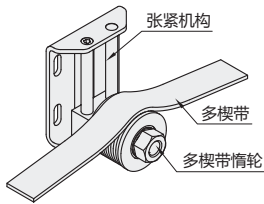
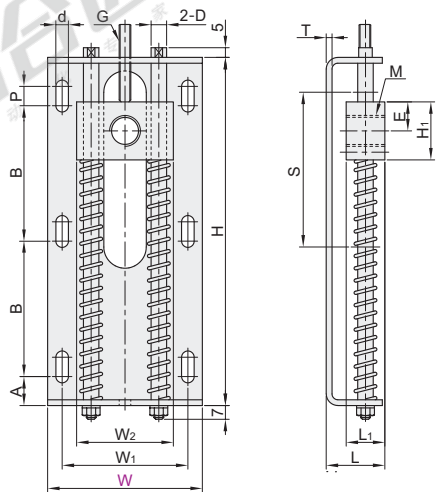

螺纹调整型/单弹簧调整型

型号		S	M	E	H	L	L <sub>1</sub>	T	d	D	A	B	G	H <sub>1</sub>	P	W <sub>1</sub>	W <sub>2</sub>
代码	W	张紧范围															
螺纹调整型 ZCL61	65	52	M10	10	80	25	16	3.2	Ø6.5	Ø8	15	40	M8	20	10	50	36
	100	70	M20	20	120	35	25	4.5	Ø9	Ø12	20	65	M12	40	15	80	60
单弹簧调整型 ZCL62	65	27	M10	10	80	25	16	3.2	Ø6.5	Ø8	15	40	M6-L35	38	10	50	36
	100	37	M20	15	120	35	25	4.5	Ø9	Ø12	20	65	M8-L50	50	15	80	60

双弹簧调整型

型号		S	M	E	H	L	L <sub>1</sub>	T	d	D	A	B	G	H <sub>1</sub>	P	W <sub>1</sub>	W <sub>2</sub>
代码	W	张紧范围															
ZCL63	80	31			100							60	M6-L40				
ZCL64	80A	80	M16	15	180	30	20	3	Ø6.5	Ø8	15	70	M6-L90	30	10	65	50

① 80A的规格仅适用ZCL64。



型号	
代码	W
ZCL61	65
ZCL62	100

ZCL61—W100



优惠价	
数量	1~9
价格	100% 另行报价



交货期	
数量	10