

免键梯形齿同步轮

◀ H型

齿距12.7

带筒易厚壁型免键胀套(带定心功能)

代码	带轮类型	皮带宽度	齿距	材质			表面处理			使用胀套代码
				带轮	法兰	胀套	带轮	法兰	胀套	
ECD41	H075	19.1	12.7	A7075	铝合金	S45C	本色阳极氧化	—	EUX16 EUX17 EUX18	
ECD43				S45C	SPCC		发黑	—		
ECD44				A7075	铝合金		本色阳极氧化	—		
ECD46				S45C	SPCC		发黑	—		
ECD48	H100	25.4	12.7	S45C	SPCC	S45C	本色阳极氧化	—	EUX16 EUX17 EUX18	
ECD49				S45C	SPCC		发黑	—		
ECD51	H150	38.1	12.7	A7075	铝合金	S45C	本色阳极氧化	—	EUX16 EUX17 EUX18	
ECD53				S45C	SPCC		发黑	—		
ECD54	H200	50.8	12.7	A7075	铝合金	S45C	本色阳极氧化	—	EUX16 EUX17 EUX18	
ECD56				S45C	SPCC		发黑	—		
ECD58	H200	50.8	12.7	A7075	铝合金	S45C	本色阳极氧化	—	EUX16 EUX17 EUX18	
ECD59				S45C	SPCC		发黑	—		



3/2

齿形 (ISO标准齿条尺寸)

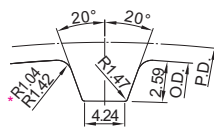

带*号R尺寸适用于19以下齿数。

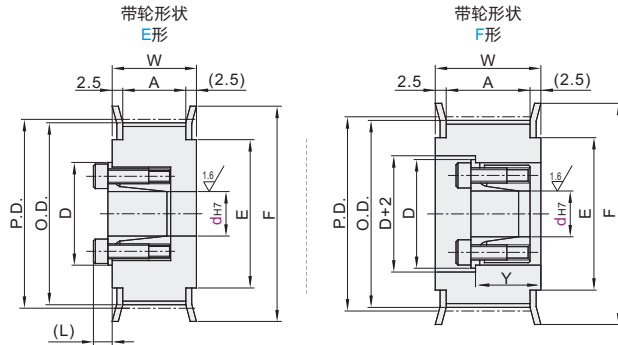

Y尺寸:
H075=Y18;
H100=d12~22时, Y=22;
d24或以上时, Y=23.5;
H150=d12~32时, Y=28;
d35或以上时, Y=32;
H200=d12~32时, Y=35;
d35或以上时, Y=39

视角标准: 第一视角

型号		带轮形状	轴孔规格dH7(根据胀套尺寸表选择)								P.D.	O.D.	F	E	A	W
代码	齿数		H075		H100		H150		H200							
			E形	F形	E形	F形	E形	F形	E形	F形						
ECD41-H075 ECD43-H075 ECD44-H075 ECD46-H100 ECD48-H100 ECD49-H100 ECD51-H150 ECD53-H150 ECD54-H150 ECD56-H200 ECD58-H200 ECD59-H200	14	E	12~16	12~16	12~16	12~16	12~16	12~16	12~16	12~16	56.60	55.22	61	45	H075 A:21 W:26	
	15		14~19		14~19		14~19	14~19	14~19	14~19	60.64	59.27	67	50		
	16		14~20		14~20		14~20	14~20	14~20	14~20	64.68	63.31	70	56		
	17		14~22		14~22		14~22	14~22	14~22	14~22	68.72	67.35	80	60		
	18		14~22	14~19		14~22	14~22	14~22	14~22	14~22	72.77	71.39	87	67		
	19		14~28		14~28	14~28	14~28	14~28	14~28	14~28	76.81	75.44	87	67		
	20		14~28		14~28	14~28	14~28	14~28	14~28	14~28	80.85	79.48	87	67		
	21		14~32		14~32	14~30	14~32	14~32	14~32	14~32	84.89	83.52	95	75		
	22		14~32		14~32	14~30	14~32	14~32	14~32	14~32	88.94	87.56	95	75		
	24		19~32	19	19~32	19~30	19~32	19~32	19~32	19~32	97.02	95.65	104	84		
	25		19~32		19~35	19~30	19~35	19~35	19~35	19~35	101.06	99.69	111	90		
	26		20~35		20~35	20~35	20~35	20~35	20~35	20~35	105.11	103.73	111	90		
	28		20~40		20~40	20~40	20~40	20~40	20~40	20~40	113.19	111.82	123	102		
	30		20~45		20~45	20~45	20~45	20~45	20~45	20~45	121.28	119.90	127	105		
	32		20~32		20~32						129.36	127.99	135	115		
	34		20~50		20~50			20~50	20~50		137.45	136.07	144	125		
	36		20~30		20~30						145.53	144.16	152	130		
	38		20~50		20~50			20~50	20~50		153.62	152.24	165	140		
40	20~50		20~50			20~50	20~50		161.70	160.33	170	150				
42	20~50		20~50			20~50	20~50		169.79	168.41	180	155				
44	20~50		20~50			20~50	20~50		177.87	176.50	190	170				
48	20~50		20~50			20~50	20~50		194.04	192.67	205	180				
50	20~50		20~50			20~50	20~50		202.13	200.76	210	185				

同步轮 F3

请按图示订货

型号		带轮形状	轴孔规格dH7	
代码	齿数		E形	F形
ECD41-H075	14	E	12~16	12~16
ECD46-H100	15	F	14~19	14~19

ECD41-H075—15—E—d15

未税价(元)

数量	1~4	5~
价格	100%	另行报价

交货期 5

胀套尺寸

dH7	容许最大扭矩N·m	D	(L)
12	44.1	28.5	
14	63.7	30.5	
15	80.4	31.5	
16	83.3	33.0	6.5
17	92.2	33.5	
18	95.1	34.5	
19	98.1	35.5	
20	216.0	42.0	
22	255.0	44.0	
24	363.0	46.0	8
25	392.0	47.0	
28	441.0	50.0	
30	500.0	52.0	8.5
32	530.0	54.0	
35	883.0	62.0	
40	1079.0	67.0	10
45	1285.0	72.0	
50	1706.0	77.0	10.5