

代码	类型	材质	表面处理
EUX41	薄壁型	S45C	—
EUX42			无电镀锌镍

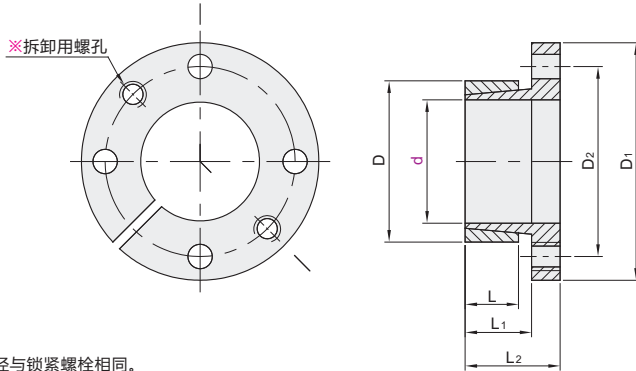

推荐安装尺寸：

轴：h8

毂：H8

符合JB/T7934 Z14型免键胀套

※拆卸用螺孔的螺径与锁紧螺栓相同。
 ① 此型号不含螺栓，如需要请特别提出。

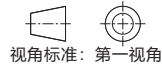

代码	型号	d	D	D ₁	D ₂	L	L ₁	L ₂	传递的轴力 Ft(KN)	传递扭矩 Ft(Nm)	接触面压强		DIN912-12.9级锁紧螺钉		
											轴	毂	数量	规格	锁紧扭矩 Ts(Nm)
EUX41	14	25	42	33	16	20	26	9	64	109	61	M4	4	2.9	
	16								73	96					
	18								82	85					
	19								87	81					
	20	30	50	39	16	20	26	15	152	127	82	M5	6		
	22								167	116					
	24								182	106					
	25								190	102					
	28	36	55	45	16	20	28	21	213	91	80	M6	10		
	30								228	85					
32	243								80						
35	266								73						
EUX42	36	44	66	54	16	20	28	40	274	71	80	M6	10		
	38								400	93					
	40								421	88					
	42								442	84					
	45	55	82	67	16	20	28	40	890	118	94	M8	25		
	48								949	110					
	50								989	106					
	55								1088	96					
60	72	99	84	16	20	28	40	1187	88	71	M8	25			
65								1286	82						

同步轮
F3



请按图示订货

型号		D
代码	d	
EUX41	14	25
EUX42	16	
	18	

EUX41-d14



Example
使用示例

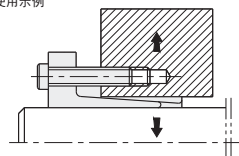

未税价(元)

优惠价	
数量	1~4 5~
价格	100% 另行报价



交货期
5