

特点

- 可防止马达在热过载或锁定转子期间烧毁，防止过负载和断相，延时，快速连接等；
- 将端子盖作为标准配置。
- 复位方法：可进行手动/自动切换具备动作显示和手动脱扣检查功能。

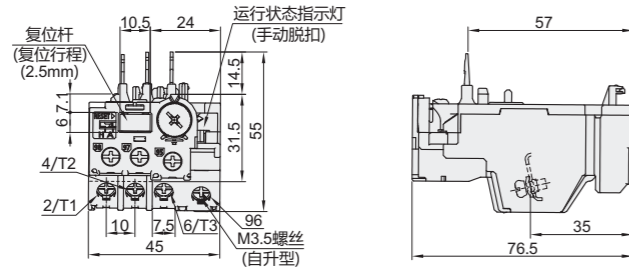

外形图：A
TH-T18KP



触头构成

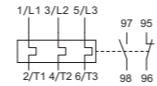

外形图：B
TH-T25KP

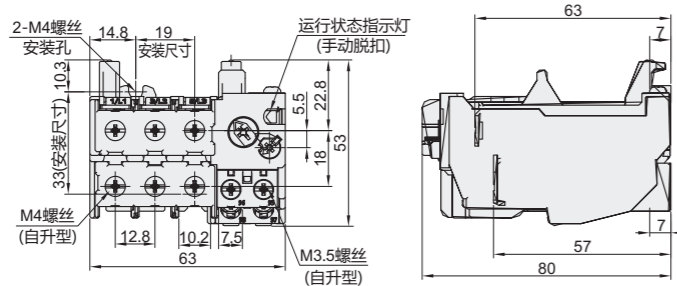

触头构成

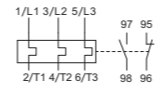

外形图：C
TH-T50KP

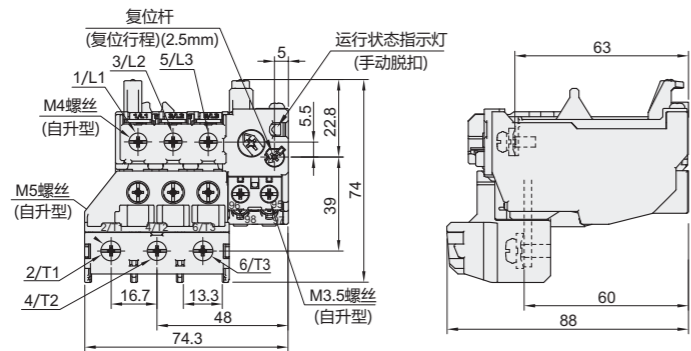

触头构成

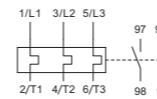

视角标准：第一视角

型号	外形图	额定电流 (A)	整定电流范围(A)	壳架等级	壳架电流	辅助触点类型	配合使用的接触器					
TH-T18KP 0.12A C	A	0.12	0.1~0.16	T18	18A	1a1b	S-T10 S-T12 S-T20					
TH-T18KP 0.17A C		0.17	0.14~0.22									
TH-T18KP 0.24A C		0.24	0.22~0.32									
TH-T18KP 0.35A C		0.35	0.28~0.42									
TH-T18KP 0.5A C		0.5	0.4~0.6									
TH-T18KP 0.7A C		0.7	0.55~0.85									
TH-T18KP 0.9A C		0.9	0.7~1.1									
TH-T18KP 1.3A C		1.3	1~1.6									
TH-T18KP 1.7A C		1.7	1.4~2									
TH-T18KP 2.1A C		2.1	1.7~2.5									
TH-T18KP 2.5A C		2.5	2~3									
TH-T18KP 3.6A C		3.6	2.8~4.4									
TH-T18KP 5A C		5	4~6									
TH-T18KP 6.6A C		6.6	5.2~8									
TH-T18KP 9A C		9	7~11									
TH-T18KP 11A C	11	9~13										
TH-T18KP 15A C	15	12~18										
TH-T25KP 3.6A C	B	3.6	2.8~4.4	T25	25A	1a1b	S-T21 S-T25 S-T35 S-T50					
TH-T25KP 5A C		5	4~6									
TH-T25KP 6.6A C		6.6	5.2~8									
TH-T25KP 9A C		9	7~11									
TH-T25KP 11A C		11	9~13									
TH-T25KP 15A C		15	12~18									
TH-T25KP 22A C		22	18~26									
TH-T50KP 29A C		C	29					24~34	T50	50A	1a1b	S-T35 S-T50
TH-T50KP 35A C			35					30~40				
TH-T50KP 42A C			42					34~50				

发热元件 标称电流 (A)	设定范围 (A)	热过载继电器 短路保护装置额定值(A)		壳架		标准三相电容量(kW)	
		保险丝gG (IEC60269-1/2)		200-220V		380-440V	
		主电路	辅助电路				
0.12	0.1~0.16	2	6				
0.17	0.14~0.22	2	6				
0.24	0.2~0.32	2	6			0.03	0.05
0.35	0.28~0.42	2	6			0.05	0.1
0.5	0.4~0.6	2	6			0.07	—
0.7	0.55~0.85	4	6			0.1	0.18
0.9	0.7~1.1	4	6			—	0.25
1.3	1.0~1.6	4	6			0.2	0.37, 0.55
1.7	1.4~2.0	6	6	T18		—	0.75
2.1	1.7~2.5	6	6		T25	0.4	—
2.5	2.0~3.0	10	6			—	1.1
3.6	2.8~4.4	10	6			0.75	1.5
5	4.0~6.0	16	6			1	2.2
6.6	5.2~8.0	20	6			1.5	3, 3.7
9	7.0~11	20	6			2.2	3, 3.7
11	9.0~13	25	6			—	5.5
15	12~18	32	6			3.7	7.5, 9
22	18~26	50	6			5.5	11
29	24~34	63	6			7.5	15
35	30~40	100	6		T50	—	18.5
42	34~50	100	6			11	22

☞ 接触器详见P165.



请按图示订货

型号
TH-T18KP 0.12A C
TK-T18KP 0.17A C
TH-T18KP 0.17A C



报价方式