

代码	WDC30600HL	WDC304-HM
安装方式	法兰底座	法兰底座
主体材质	铸钢	铸钢
表面处理	发黑	发黑
夹持力(kg)	650	680
行程	32	60
把手转角	185°	180°
自重(g)	610	1480
附件(压头螺丝)	WDM-086512	WDM-125017

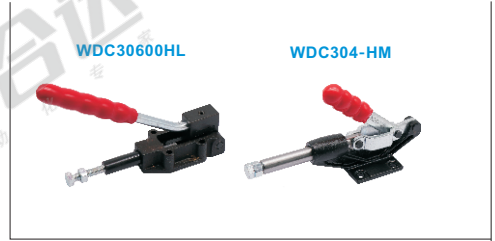

WDC30600HL

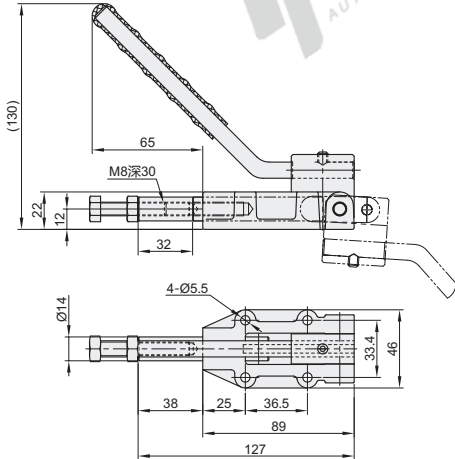

WDC304-HM

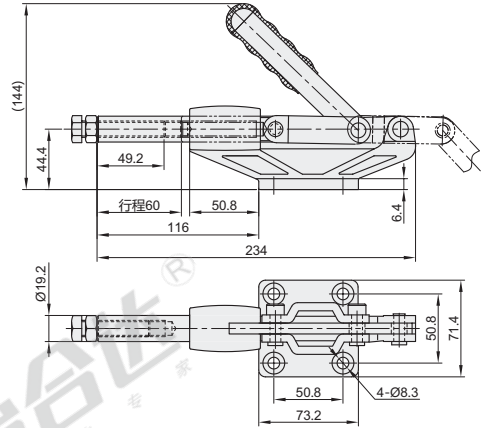

视角标准：第一视角

快速夹钳

H3

代码	WDC3630M	WDC31200-HL
安装方式	法兰底座	法兰底座
主体材质	SS400	铸钢
表面处理	镀锌	发黑
夹持力(kg)	1136	1200
行程	50.8	50
把手转角	180°	185°
自重(g)	935	1500
附件(压头螺丝)	WDP-105015	WDM-107515

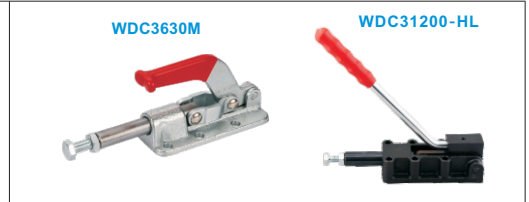

WDC3630M

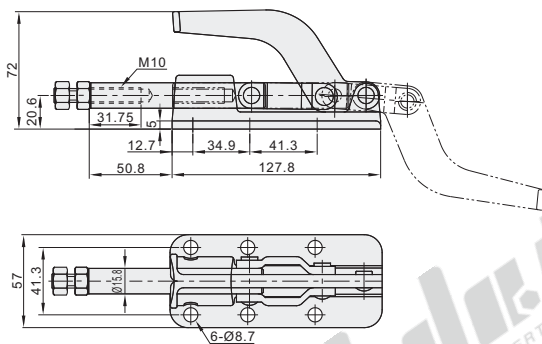

WDC31200-HL

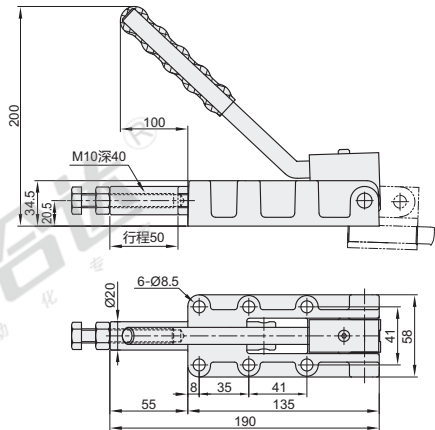

视角标准：第一视角



型号
WDC30600HL



● 优惠价
数量 1~9 10~
价格 100% 另行报价



交货期
5