

机械防护栏30/40系列配件

■ 推拉门拉手

代码	类型	材质	表面处理
AVL46	推拉门拉手	锌合金	浅灰色烤漆
AVL47			黑色烤漆

❗ 将推拉门拉手安装于推拉门上，便于推拉门的开启和闭合，可将推拉门锁紧。

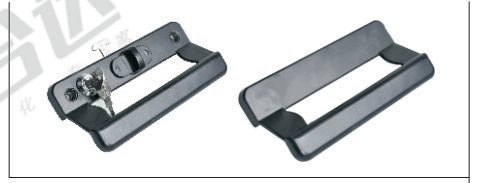

AVL46-P-L
AVL47-P-L

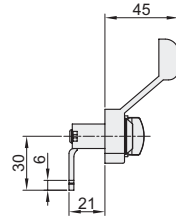
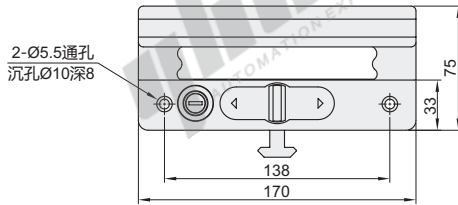

❗ 备注：配套使用配件AVJ02-K。

AVL46-P-R
AVL47-P-R

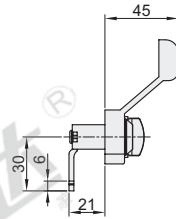
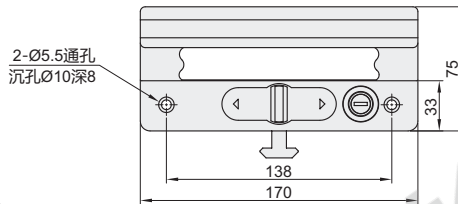

❗ 备注：配套使用配件AVJ02-K。

AVL46-W
AVL47-W

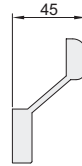
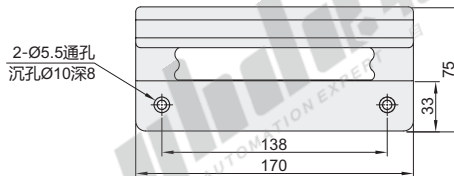

代码	重量(g/pcs)
AVL46-P-L	494
AVL47-P-L	
AVL46-P-R	
AVL47-P-R	
AVL46-W	206
AVL47-W	

视角标准：第一视角

EX Example 使用示例

分解图

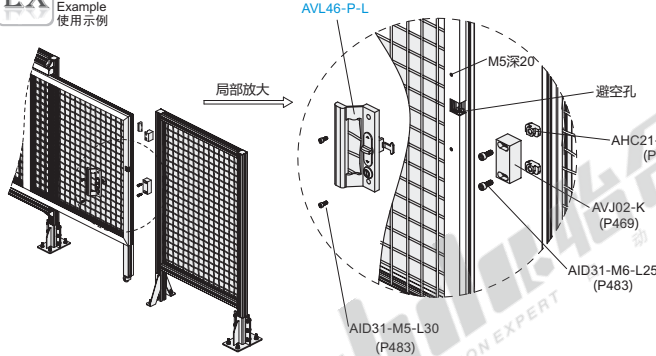

组装图

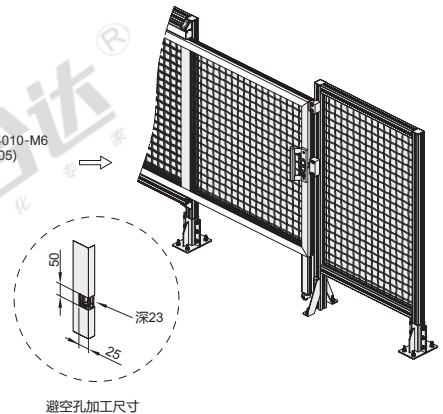

请按图示订货

型号
AVL46-P-L
AVL47-P-L

报价
方式

