

角连接件

| 代码 | 类型 | 材质 | 表面处理 |
|-------|------|-------|------|
| AYH11 | 角连接件 | ADC12 | 光饰 |

- ① 用于型材30°、45°、60°的连接。
- ② 产品含盖板、内六角沉头螺钉。

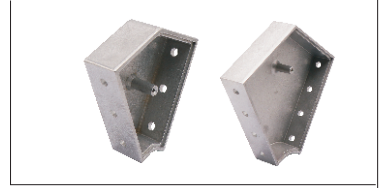

AYH11-120-30

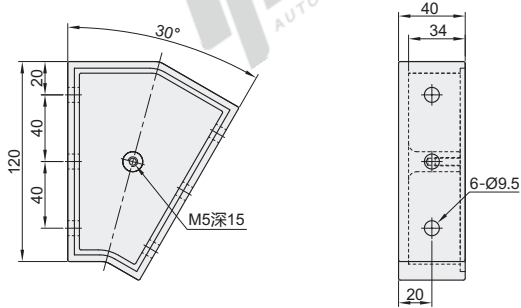

盖板(配套使用)

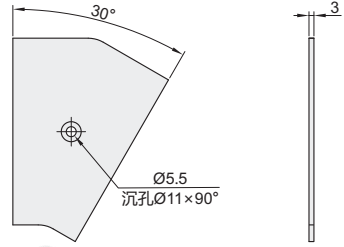

AYH11-120-45

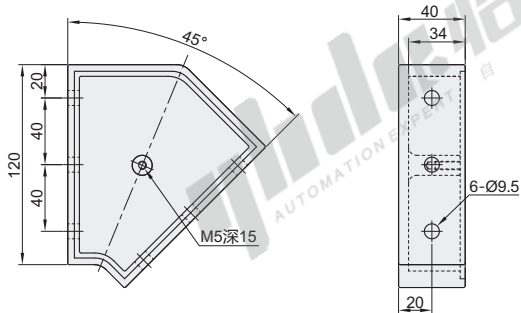

盖板(配套使用)

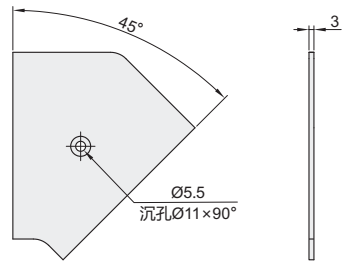

AYH11-120-60

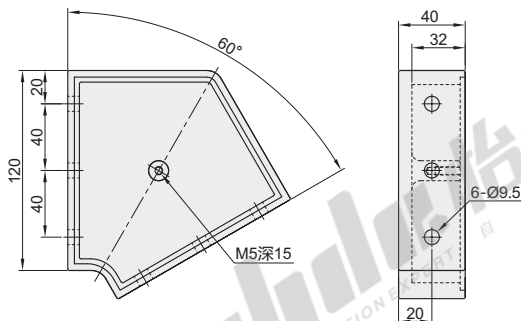

盖板(配套使用)

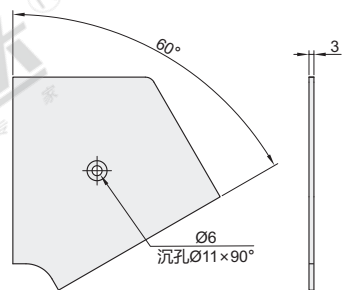

AYH11-160-30

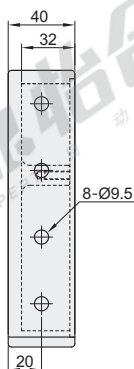
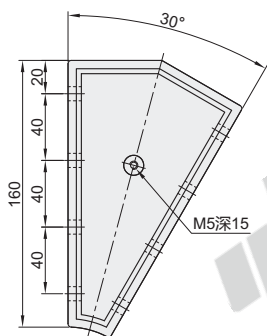

盖板(配套使用)

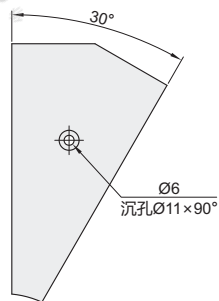

AYH11-160-45

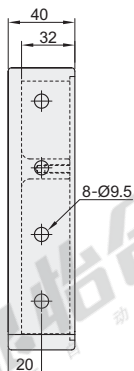
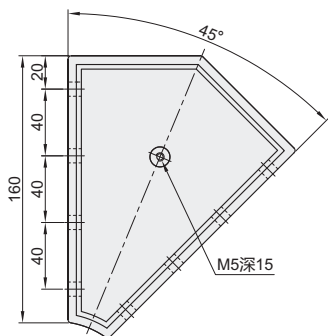

盖板(配套使用)

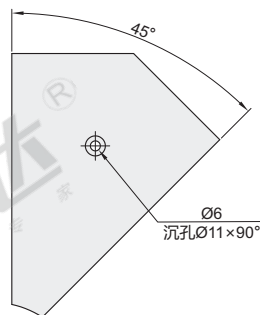

AYH11-160-60

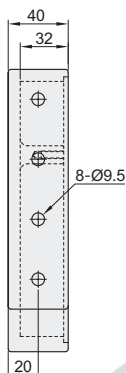
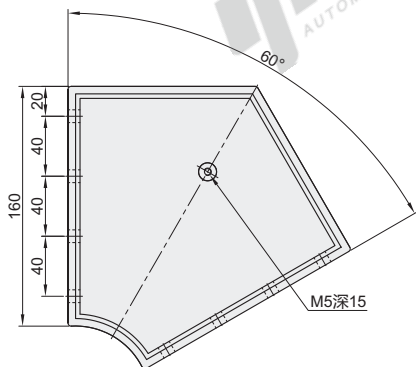

盖板(配套使用)

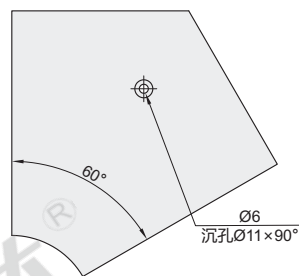

视角标准：第一视角

| 代码 | 重量(g/pcs) |
|--------------|-----------|
| AYH11-120-30 | 395 |
| AYH11-120-45 | 457 |
| AYH11-120-60 | 800 |
| AYH11-160-30 | 537 |
| AYH11-160-45 | 632 |
| AYH11-160-60 | 1046 |



可选加工

型号 AYH11-160-45-SET-A AYH11-160-45-SET-B
AYH11-160-45-SET-C

| 增加加工项目 | 代码 | *使用方式 | 技术说明 |
|----------------|-------|-------|---|
| 配备合适的螺钉、螺母和螺纹套 | SET-A | A | 螺钉：TAH15-M8-L20 螺纹套：AIP31-M8-N12-L20 |
| | SET-B | B | 螺钉：TAH15-M8-L16 TAH15-M8-L20 螺纹套：AIP31-M8-N12-L20 T型螺母：AHC21-4010-M8 |
| | SET-C | C | 螺钉：TAH15-M8-L20 螺纹套：AIP31-M8-N12-L20 |



请按图示订货

型号

AYH11-120-30
AYH11-120-45
AYH11-120-60

报价方式



*使用方式详见下页图示。

EX

Example
使用示例

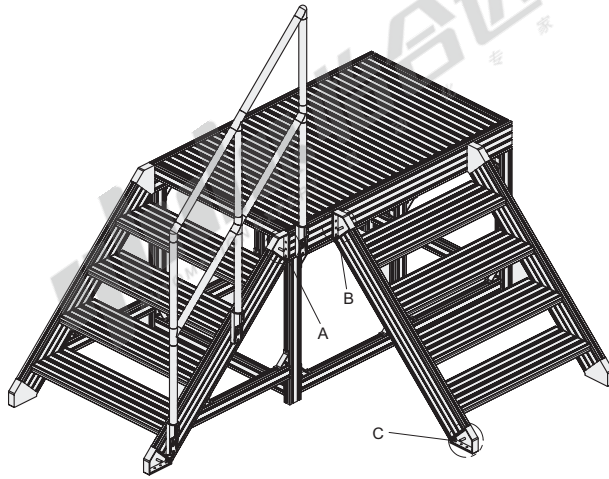

使用方式A

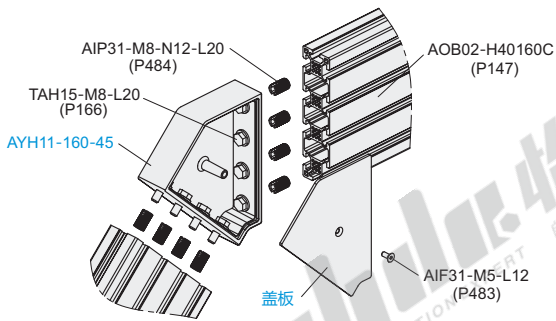

使用方式B

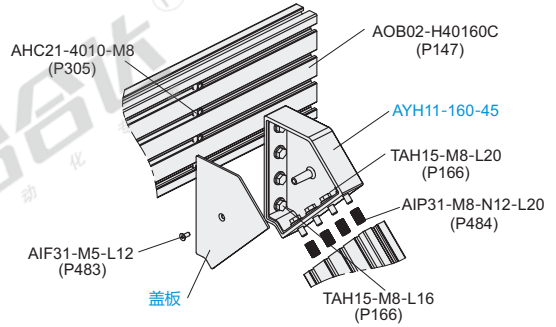

使用方式C

