

代码	类型		材质	表面处理
HGA66	强紧固力	中载型	SUS304	震动抛光
HGA67	超强紧固力	超高载型		
HGA70			碳钢	
HGA60	螺纹调节型	重载型	SUS304	

中载型
HGA66

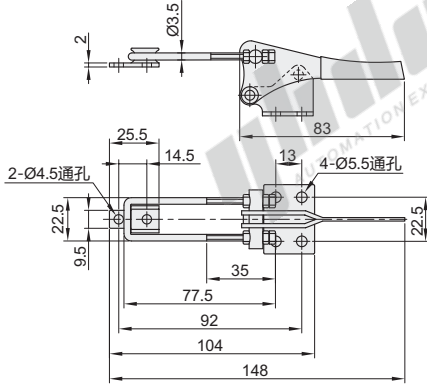

安装孔间距

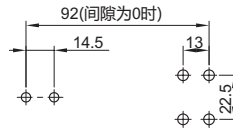

超高载型
HGA67

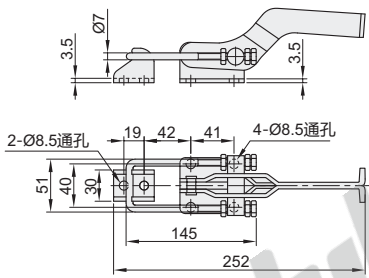

安装孔间距

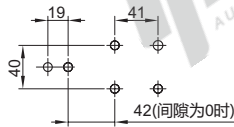

超高载型
HGA70

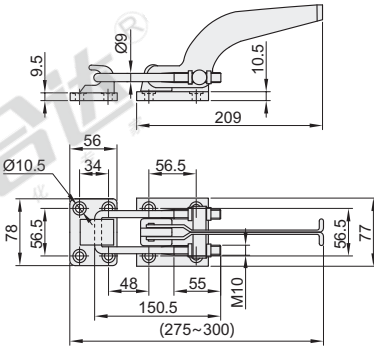

安装孔间距

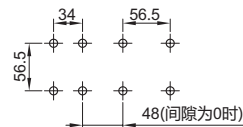

重载型
HGA60

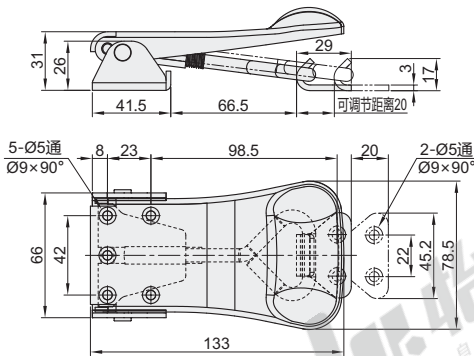

安装孔间距

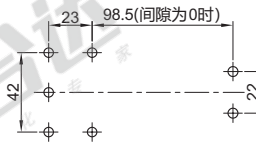

视角标准：第一视角

型号		拉伸承重	参考重量
代码	规格	(kgf)	(kg/pcs)
HGA66	148	95	0.094
HGA67	252	500	0.64
HGA70	300	1818	1.33

型号		参考重量
代码	规格	(kg/pcs)
HGA60	133	0.44



请按图示订货



未税价(元)

型号		规格
代码	规格	
HGA66	<42	
HGA67	252	
HGA66—148		

● 优惠价

数量	1~9	10~
价格	100%	另行报价



交货期

1

HGA66/67/70



交货期

3

HGA60