

防震脚杯

万向调节型·全橡胶底座型 超重载型

代码	类型	材质			表面处理	
		外罩	螺杆	底部	外罩	螺杆
WAG71	全橡胶底座型	SUS304	SUS304	橡胶	—	—
WAG73		S45C	S45C	橡胶	镀锌	镀锌
WAG74					镀铬	镀铬

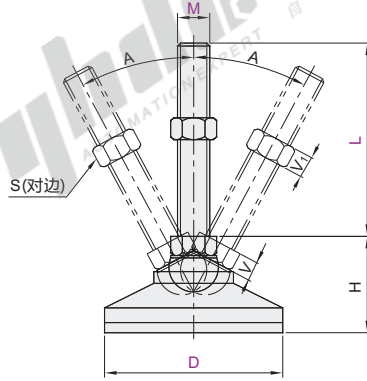

型号		M	L	S	V	V ₁	H	A	承载 (Kg)	参考重量 (Kg/pcs)
WAG71 WAG73 WAG74	60	12	50	19	8	10	38		1600	0.45
			75							0.46
			100							0.47
		80	16	125	24	10	13	41	1800	0.5
				75						0.47
				100						0.48
	100		20	125	30	13	16	48	2000	0.51
				150						0.54
				100						0.55
		120	24	125	36	16	19	48	4000	0.58
				150						0.61
				100						0.67
	150		30	125	46	24	24	5000	5000	0.63
				150						0.66
				100						0.67
		200	20	125	30	13	16	48	2000	0.67
				150						0.7
				100						0.74
	250		24	125	36	16	19	48	4000	0.7
				150						0.74
				100						0.77
		300	30	125	46	24	24	5000	5000	0.78
				150						0.82
				100						0.88
400	40		125	60	32	32	6000	6000	0.82	
			150						0.94	
			100						0.97	
	500	50	125	75	40	40	7500	7500	0.94	
			150						1.04	
			100						1.08	
600		60	125	90	50	50	9000	9000	1.08	
			150						1.12	
			100						1.18	
	800	80	125	120	66	66	12000	12000	1.14	
			150						1.22	
			100						1.28	

脚杯



型号			
代码	D	M	S
WAG71	400	20	30

WAG71—D100—M20—L100



优惠价	
数量	价格
1~9	100%
10~	另行报价



1